

Institch-i5 Electric Control System

Operation Instruction

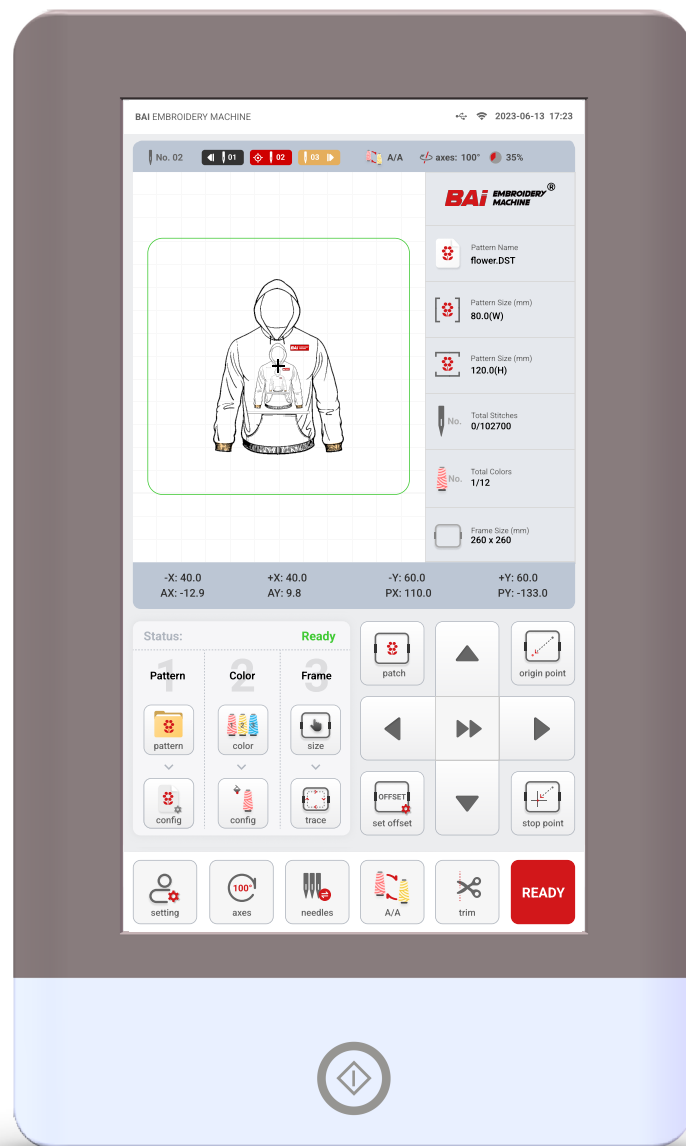

Controller	3	Setting	40
Preparation	4-9	Language	42
Pattern management	10-11	Time	43
How to Input patterns	12	Statistics	44
How to output patterns	13	Test	45-46
Letter embroidery	14-16	How to test machine head's board	47-48
How to embroider letters	17	Machine settings	49-52
Pattern division	18	Trimming setting	53-54
How to divide patterns	19	Thread breakage setting	55-56
Pattern combination	20-21	Speed setting	57-58
How to combine patterns	22	Frame setting	59
Edit pattern	23-25	Add frame manually	60-63
How to edit pattern	26	WI-FI	64
Color setting	27-28	Find the origin	65
How to set colors	29	How to find the origin	66
Needle color setting	30	Screen calibration	67
How to set needle colors	31	Power-off recovery	68
Choose frame	32-33	System	69-70
Quickly add embroidery frames	34-35	Common failures and solutions	71-72
Track location	36-37		
Embroidery state	38-39		

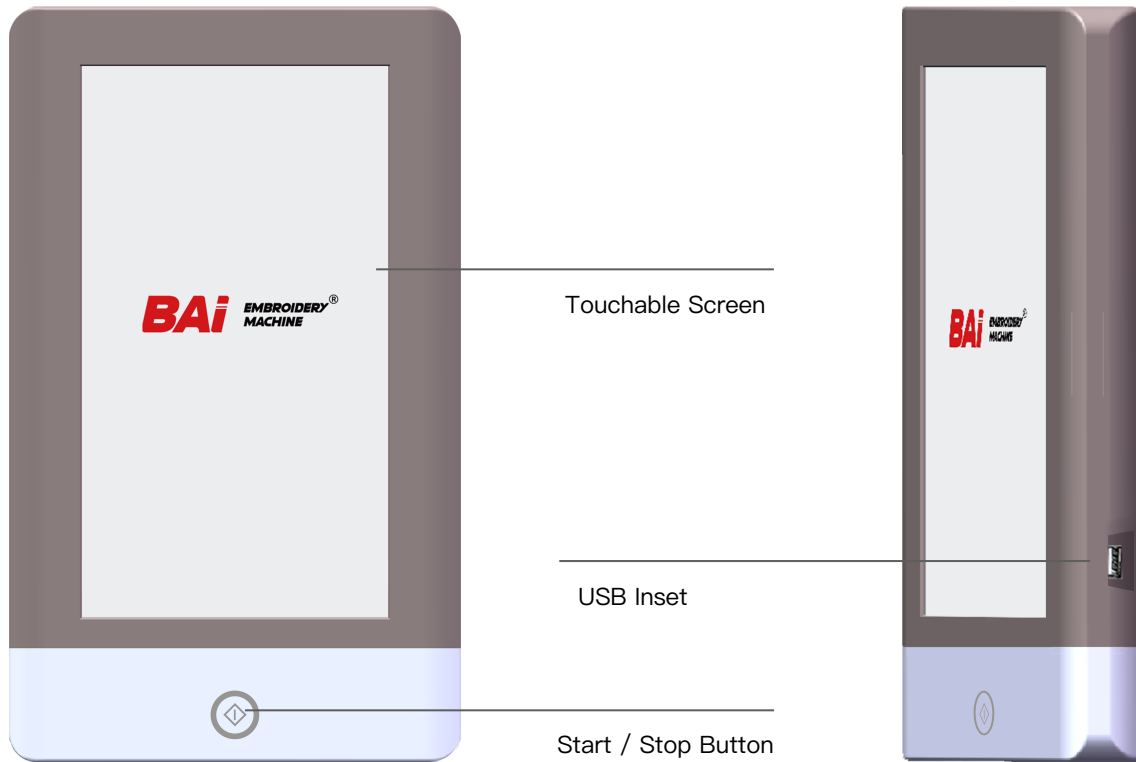

Contents

Description

Touchable Screen	High brightness LCD display and touch screen.
USB Inset	USB insert for patterns input and output.
Start / Stop Button	Click button to start and stop embroidery.

Tips :



- For ensuring the service life and use of the touch screen, please do not tap the screen with hard and sharp objects.
- Do not click too hard when tapping to avoid damaging the touch screen.

Tips :

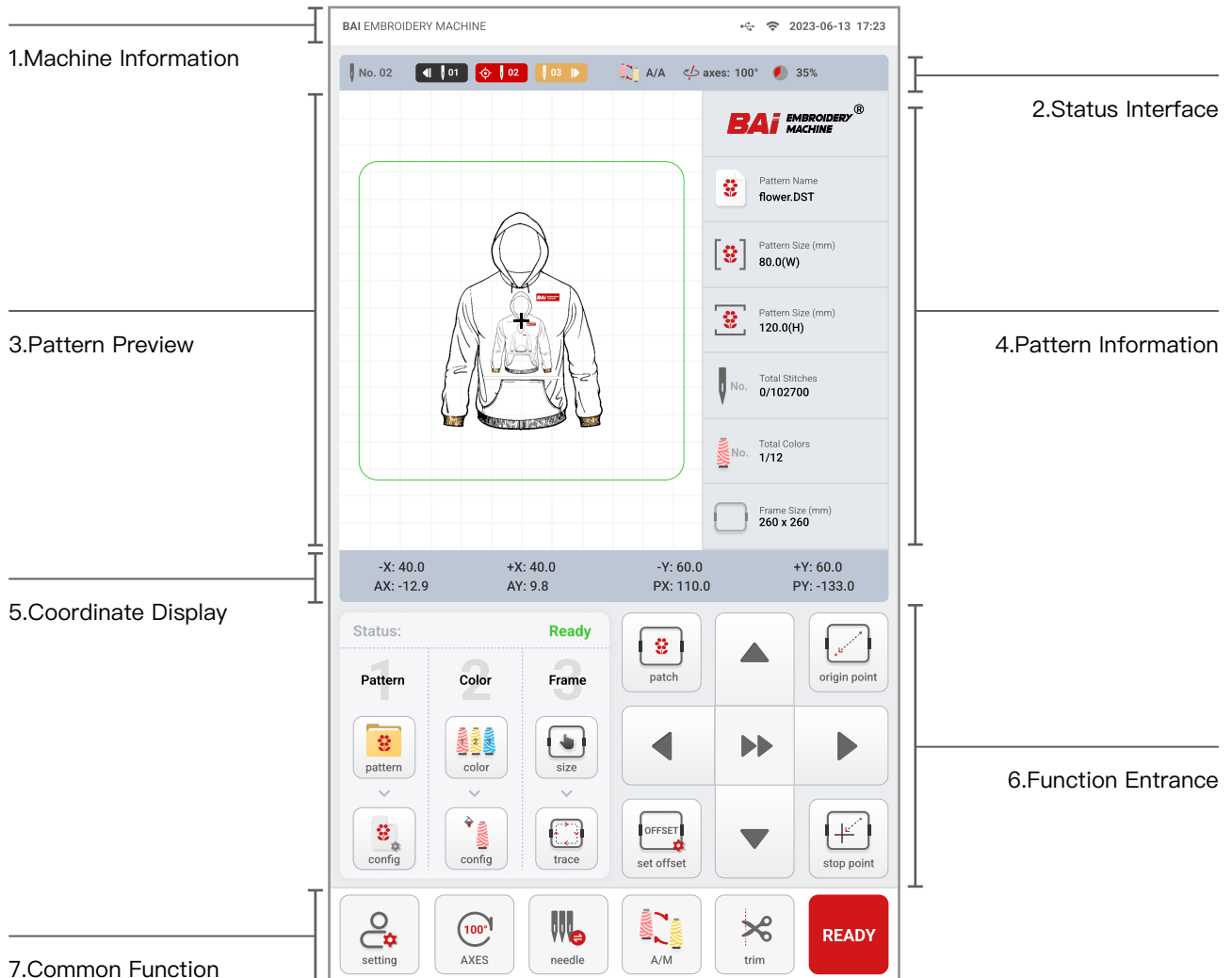





- Please insert and remove USB with right direction.
- Do not pull out USB when reading, in case data lost.



1. Machine Information

Contents	Description
	Signal intensity.
	USB connection status.
Time	Change time display method in setting page.





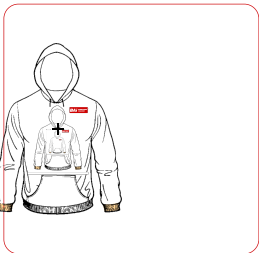

2. Status Interface

Contents	Description
 No. 02	<p>Current needle position.</p> <ul style="list-style-type: none">i If “00”, it is “No Needle”. Turn the color change motor knob by hand until screen shows any number but “00”.
	<p>Color display: After choose colors for pattern, will show here.</p> <ul style="list-style-type: none">1 is last color.2 is present color.3 is next color.
	<p>3 color changing modes of embroidery.</p> <ul style="list-style-type: none">A/A is auto color changing and start embroidery.A/M is auto color changing and manual start embroidery.M/M is manual color changing and manual start embroidery.
 axes: 100°	<p>Main axis degree display.</p> <ul style="list-style-type: none">i If “???” or other numbers, it is main axis not in place.i Click 100° at the bottom page to make it back to normal. 
 35%	Completion ratio.

3. Pattern Preview

Contents	Description
 	<p>Display the position of the pattern in frame you selected.</p> <ul style="list-style-type: none">When the pattern is within the frame, the border line is green.When the pattern out of the frame, the border line is red.

4. Pattern Information

Contents	Description
 Pattern Name flower.DST	Pattern's name and format.
 Pattern Size (mm) 80.0(W)	Pattern's width.
 Pattern Size (mm) 120.0(H)	Pattern's height.
 Total Stitches 0/102700	Completed stitches / Total titches.
 Total Colors 1/12	Completed colors / Total colors.
 Frame Size (mm) 260 x 260	Frame's type and area.

5. Pattern Information

Contents

-X: 40.0	+X: 40.0	-Y: 60.0	+Y: 60.0
AX: -12.9	AY: 9.8	PX: 110.0	PY: -133.0

Description

(1) Coordinate display of pattern.

- Pattern's width is -X plus +X values.
- Pattern's height is -Y plus +Y values.





(2) Coordinate display of relative origin of pattern and frame.



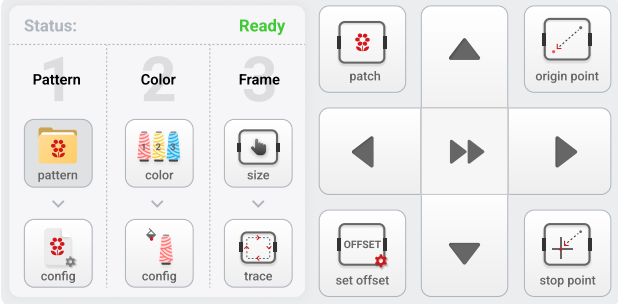
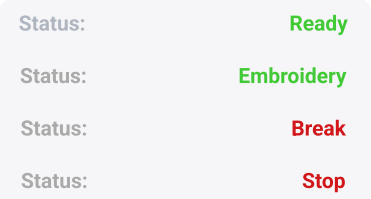

- AX/AY: coordinate display of relative origin of pattern.
- PX/PY: coordinate display of relative origin of frame.

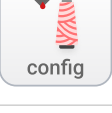
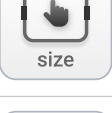
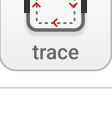

6. Function Entrance

Contents





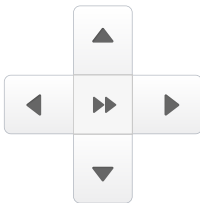

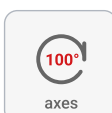

Description

Contents	Description
	<p>This section provides all the functions of preparation work before embroidery.</p>
	<p>Working status:</p> <ol style="list-style-type: none"> Ready. Embroidery. Break. Stop.
	<p>Pattern selection, input, output, division, combination, and deletion.</p> <ul style="list-style-type: none"> ❖ Detailed introduction: P10
	<p>Rotating, Mirroring, Arraying, etc. on the pattern.</p> <ul style="list-style-type: none"> ❖ Detailed introduction: P23
	<p>Setting pattern color.</p> <ul style="list-style-type: none"> ❖ Detailed introduction: P27
	<p>Set needle bar number and thread color.</p> <ul style="list-style-type: none"> ❖ Detailed introduction: P30
	<p>Select the corresponding embroidery frame according to pattern.</p> <ul style="list-style-type: none"> ❖ Detailed introduction: P32
	<p>Positioning before starting embroidery.</p> <ul style="list-style-type: none"> ❖ Detailed introduction: P36

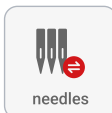
Contents	Description
 <p>set offset</p>	<p>Set offset point: When make appliqué , press it to set the stop point after going out of the frame.</p> <ol style="list-style-type: none"> 1. Move the embroidery frame to the specified position. 2. Click the set offset key. 3. Click OK. <p>i When no offset point is set, the highest point of the current embroidery frame is automatically defaulted as the offset point.</p>
 <p>patch</p>	<p>Quick appliqué: Every time you press the key, move alternately between the current position and the offset point.</p> <ul style="list-style-type: none"> • In the stop state, click the button to move the embroidery frame from the stop point to the offset point. After putting appliqué and so on steps, directly start the machine, the frame will return to the stop point, and continue to embroider.
 <p>origin point</p>	<p>Return to origin point:Restart embroidery after returning to the origin point.</p> <p>i In the state of embroidery, if you click to return to the origin point, the embroidery will over, and return to the starting point, please select as needed.</p>
 <p>stop point</p>	<p>Return to stop point:During the embroidery process, when it is necessary to go out of the frame for manual add appliqué or other operations.</p> <ol style="list-style-type: none"> 1.Pause the machine first. 2.Use the direction keys on the screen to move the position of the frame. 3.When the manual appliqué or other operations are completed, click the key to return to the stop point again, and the embroidery frame will automatically return to the pause position. 4.Click the start key, and the machine will automatically start embroidery from the last stop position. <p>i During operation, the embroidery frame and fabric cannot be removed, otherwise the last stop point won't be accurate.</p> <p>i After power off, please click the recovery key to continue embroidery.</p> <p>❖ Power off recovery: P68</p>

Contents	Description
	<p>Move the position of the pattern in frame.</p> <ul style="list-style-type: none"> • speed selection key. •  High speed move /  Low speed move

7. Common Function

Contents	Description
	<p>Set machine parameters.</p>
	<p>Main axis 100° key.</p> <ul style="list-style-type: none"> • You can see the degree of main axis in the embroidery information area. •  If “???” or other numbers, it is main axis not in place, click this key to bring it back to normal.
	<p>Click the key to manually switch needle positions.</p> <ul style="list-style-type: none"> •  If “00”, it is “No Needle”. Turn the color change motor knob by hand until screen shows any number but “00”.
	<p>3 color changing modes of embroidery.</p> <ul style="list-style-type: none"> • A/A is auto color changing and start embroidery. • A/M is auto color changing and manual start embroidery. • M/M is manual color changing and manual start embroidery.
	<p>Thread trimming: Manual thread trimming.</p>
	<p>Working state switching key(READY/EMB).</p> <ul style="list-style-type: none"> • Press the key alternately. •  Ready is ready state, pattern selection must be done in the Ready state. •  Emb means to enter the working state, only in this state can start embroidery.

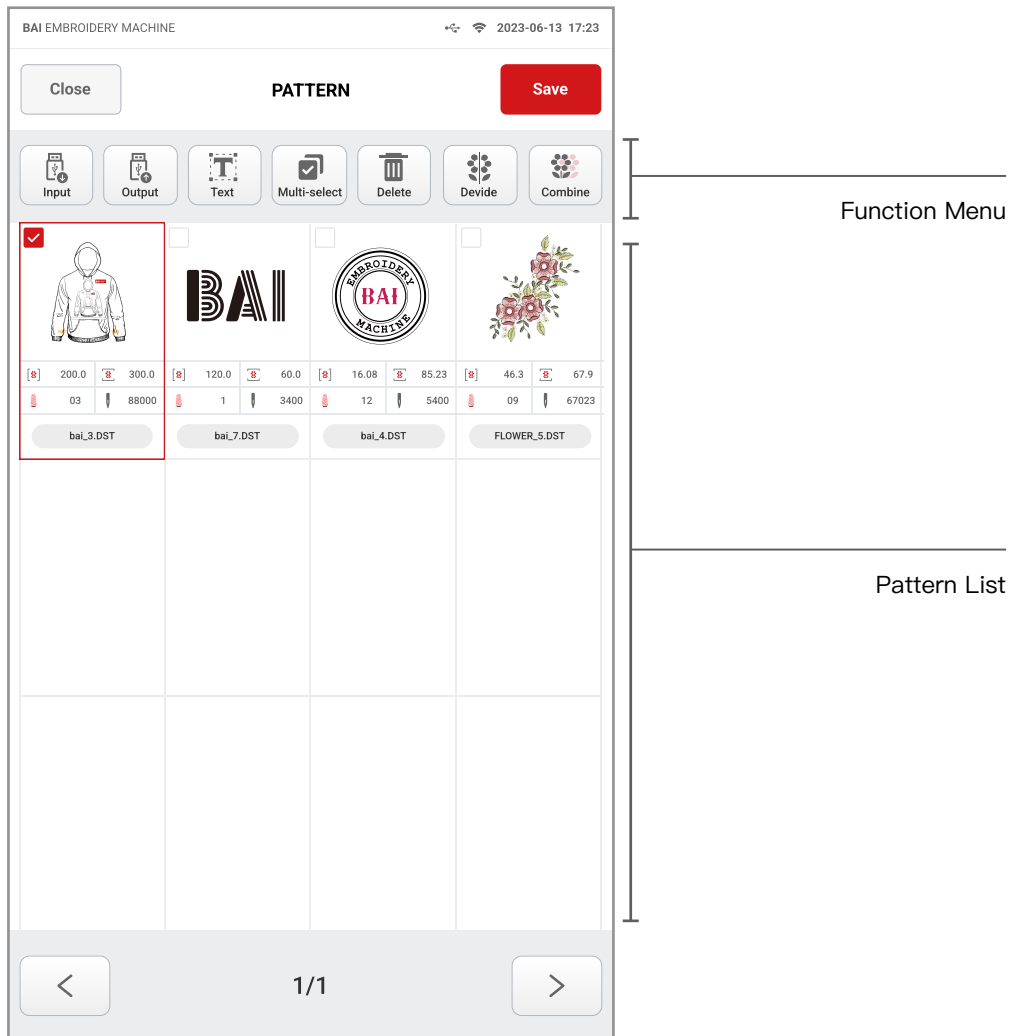

Function Menu

Contents

Description



Input

Input patterns with USB.

- Input the USB, click input key, select the pattern in the USB, click save, and the pattern will be saved in the pattern management.





❖ Detailed introduction: P12



Output





Patterns output to USB.

❖ Detailed introduction: P13

Contents	Description
	<p>Letter embroidery: Click to enter the letter editing interface.</p> <ul style="list-style-type: none"> ❖ Detailed introduction: P14
	<p>Multiple select: Batch import, output and delete patterns.</p> <ul style="list-style-type: none"> • It is usually used in importing , outputing , and deleting patterns.
	<p>Delete: Delete the pattern after selecting it.</p>
	<p>Divide: After selecting the pattern, click to enter the pattern division editing.</p> <ul style="list-style-type: none"> ❖ Detailed introduction: P18
	<p>Combined: Select patterns and click Save to enter the combined pattern editing interface.</p> <ul style="list-style-type: none"> ❗ Up to 4 patterns can be selected for combination. ❖ Detailed introduction: P20

Pattern List

Contents

<input checked="" type="checkbox"/>	<input type="checkbox"/>	<input type="checkbox"/>	<input type="checkbox"/>
			
[8] 200.0 [8] 300.0	[8] 120.0 [8] 60.0	[8] 16.08 [8] 85.23	[8] 46.3 [8] 67.9
[8] 03 [8] 88000	[8] 1 [8] 3400	[8] 12 [8] 5400	[8] 09 [8] 67023
ba1_3.DST	ba1_7.DST	ba1_4.DST	FLOWER_5.DST

Description

- (1) Pattern files can be multi or single-selected.
- (2) The width, height, total number of colors, total stitches and name of the pattern will be displayed under the pattern.

How to Input Patterns

12

1 Insert USB.

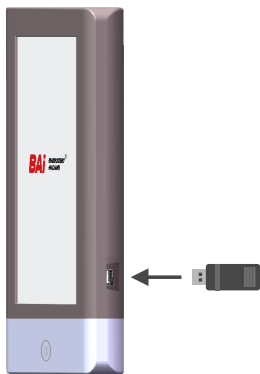

2 Click

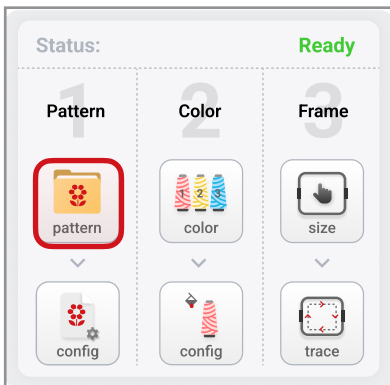

3 Click

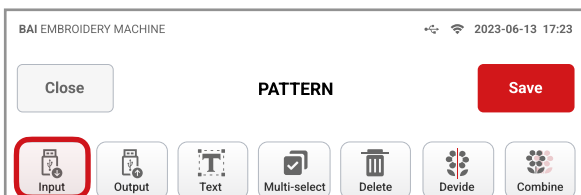

4 Select the patterns to inputted.

- The default is **multi-selection**, you can select multiple patterns at the same time to input together.

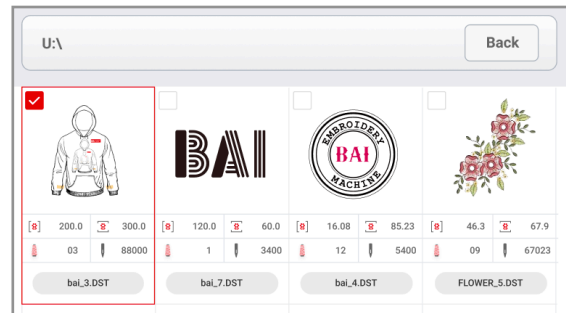

5 Click import key

Import

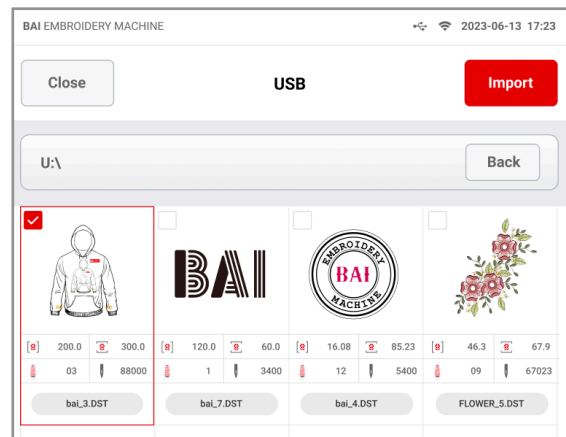

i Tips :

- When inputting, if USB can't be read, please re-plug or replace USB to input again.
- The USB storage space needs to be less than 64Gb, and the format is Fat32.
- This machine supports the storage of up to 200 deigns or 20 million stitch . If there is not enough space, delete some patterns before continuing to input.
- Do not remove the USB before the input is complete to avoid data loss.
- This machine supports pattern files in DST/DSB format, other formats need to be converted by design software.

How to Output Patterns

1 Insert USB.

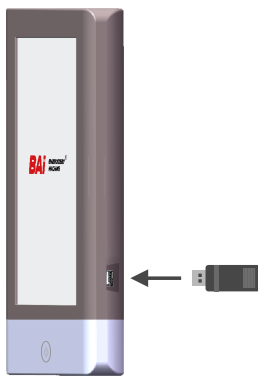

2 Click 

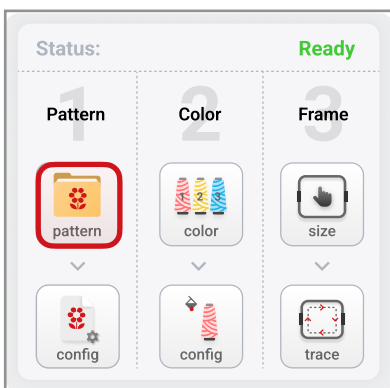

3 Select the patterns to be outputted.

- The default is **single selection**.
- If you need to output multiple patterns at one time, click multi-select key. 

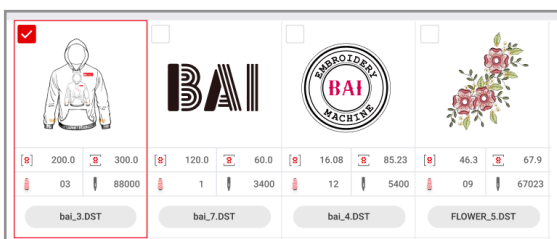

4 Click 

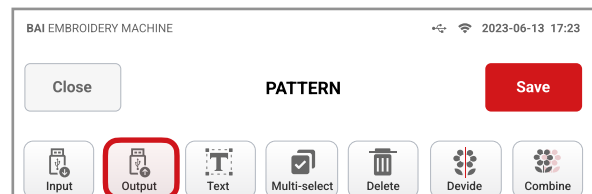

i Tips :

- If you need to output all patterns, please click directly. 

i Tips :

- When outputting, if USB can't be read, please re-plug or replace USB to input again.
- Do not remove the USB until the output is complete to avoid data loss.

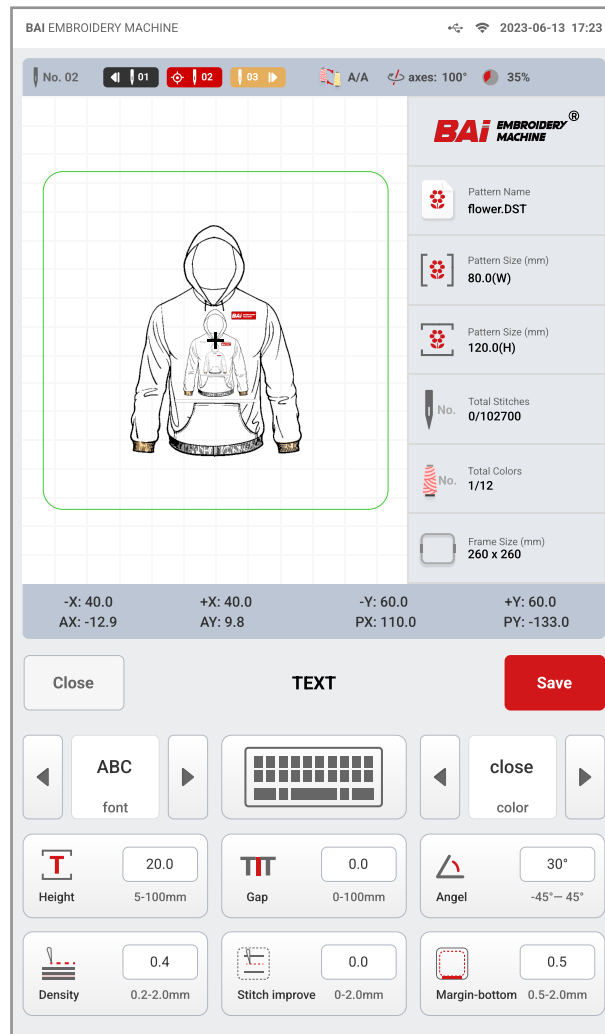

Contents

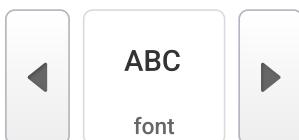













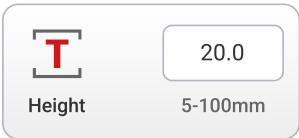

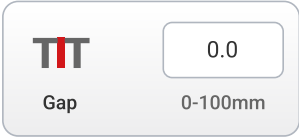
Description

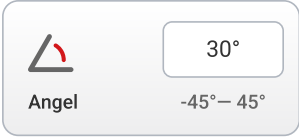
Letter fonts.

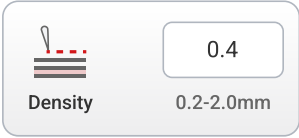
- Supports 10 fonts, which can be switched by clicking the left and right keys.

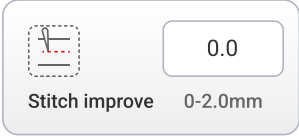
Keyboard input area.

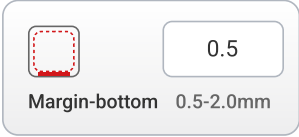
-  click on the keyboard input area to bring up the numeric keyboard to write letters.

Contents	Description
 <p>close color</p>	<p>Color change switch.</p> <ul style="list-style-type: none">• When close, the pattern has only one color at this time.• When open, each individual letter will have a random color.
 <p> Height 20.0 5-100mm</p>	<p>Letter height adjustment.</p> <ul style="list-style-type: none">• Adjustable range 5-100mm.
 <p> Gap 0.0 0-100mm</p>	<p>Letter spacing adjustment.</p> <ul style="list-style-type: none">• Adjustable range 0- 100mm.
 <p> Angel 30° -45° - 45°</p>	<p>Letter rotation angle adjustment.</p> <ul style="list-style-type: none">• Adjustable range -45° — 45°.
 <p> Density 0.4 0.2-2.0mm</p>	<p>Stitch spacing: Can adjust the size of the stitch spacing of letters.</p> <ul style="list-style-type: none">• The spacing setting for normal embroidery is 0.3 - 0.4mm, the smaller the value, the denser the pattern, vice versa.• Adjustable range 0.2-2.0mm.
 <p> Stitch improve 0.0 0-2.0mm</p>	<p>Stitch improve: Used to improve embroidery quality, according to different fabrics and patterns size to adjust.</p> <ul style="list-style-type: none">• Adjustable range 0-2.0mm.
 <p> Margin-bottom 0.5 0.5-2.0mm</p>	<p>Margin bottom: Used to stabilize the fabric and reduce embroidery distortion due to shrinkage and avoid sinking into soft fabrics.</p> <ul style="list-style-type: none">• The default setting is 0.5mm, the more shrinkage of the fabric, the smaller the distance of the margin bottom.• The adjustable range is 0.5-2.0mm.

Stitch Improve Example

The default setting is 0mm.

- The more the shrinkage of the fabric or the pattern, the bigger stitch improve value will be set.

i Affected by the fabric used, it needs to be adjusted according to the actual situation.

i The following is for reference only.

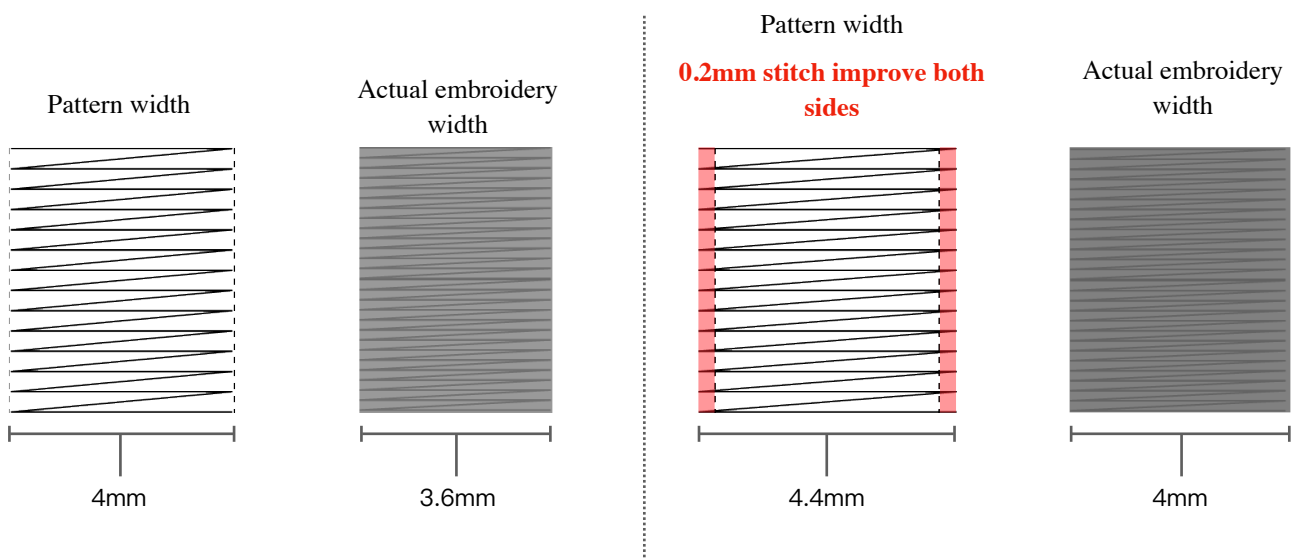

Margin-Bottom Example

The default setting is 0.5 mm.

- The more shrinkage of the fabric, the shorter the distance of the margin bottom.

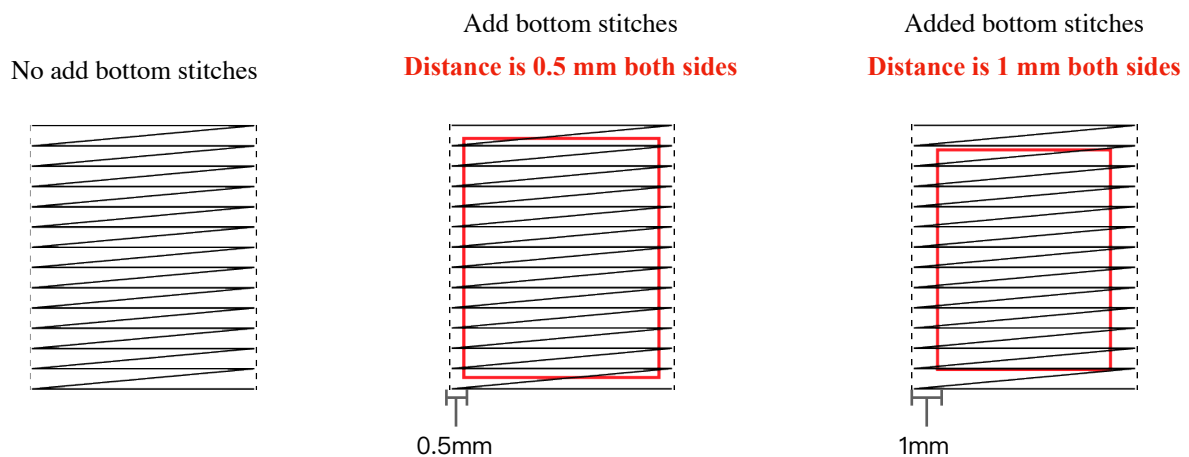

How To Embroider Letters

17

1 Click 

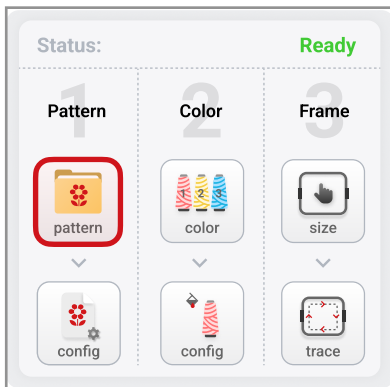

2 Click 

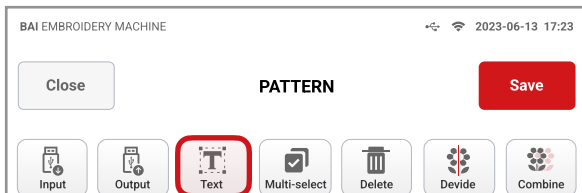

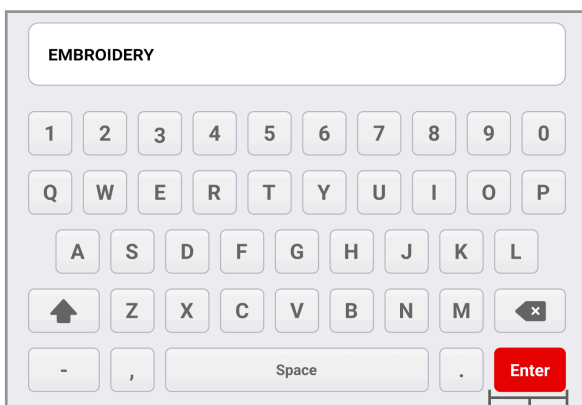

3 Enter letters 

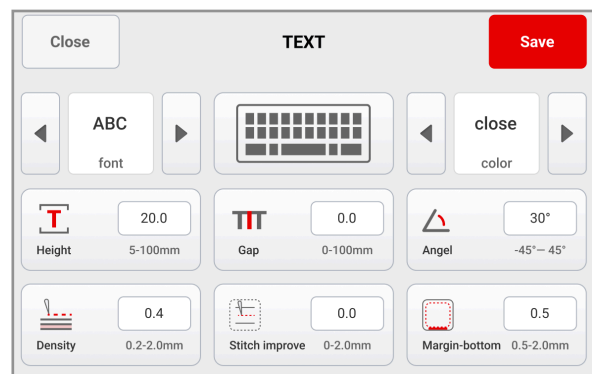

Enter Key

4 Edit letters as request.



5 After adjustment, click 

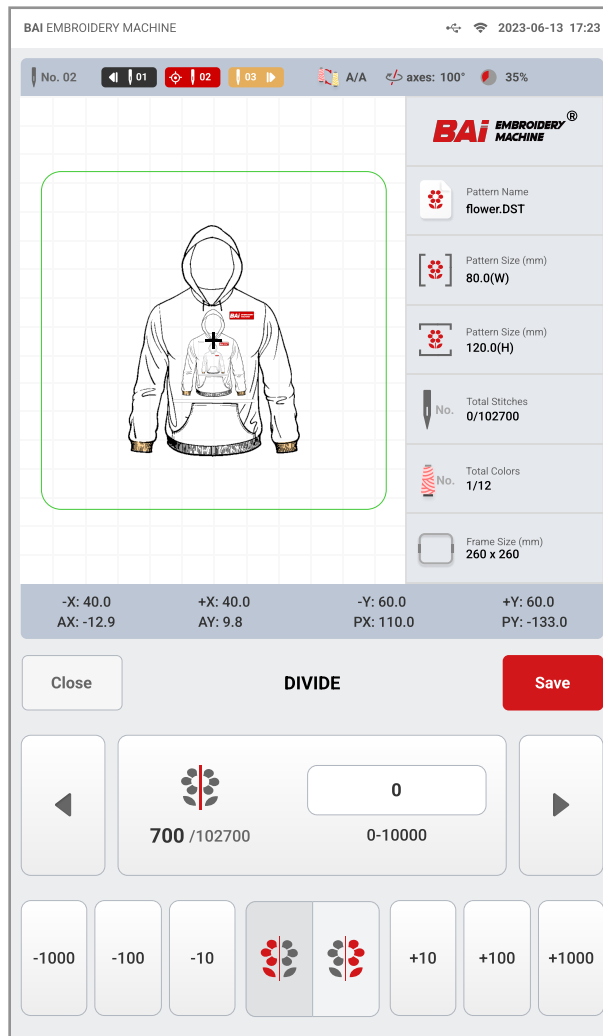

Contents

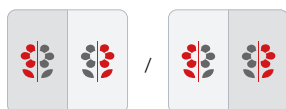
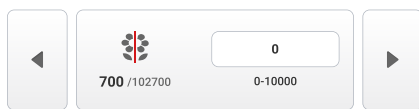

Description

Customize the division of stitches.

- Input the specific number of stitches, and click the left and right switching keys to divide.

Divide the pattern with specific number.

- Only the system default number of stitches can be selected for division.

Check out the divided preview area.

- Press the left side to preview the first half of the pattern.
- Press the right side to preview the second half of the pattern.

How To Divide Patterns

1 Click 

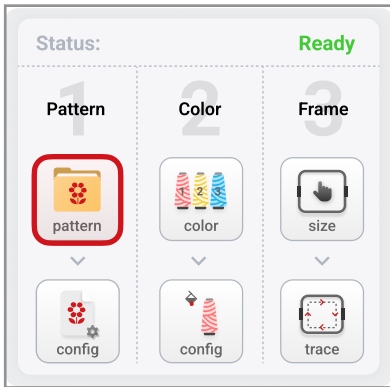

2 Choose the pattern to be divided.

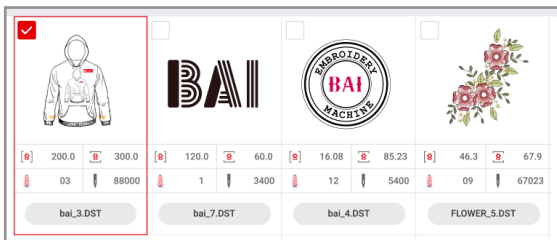

3 Click 

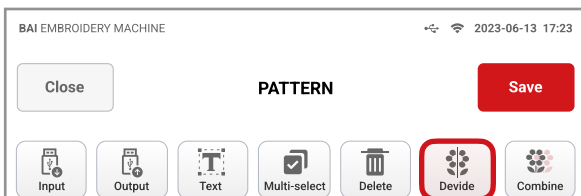

4 Divide as request.

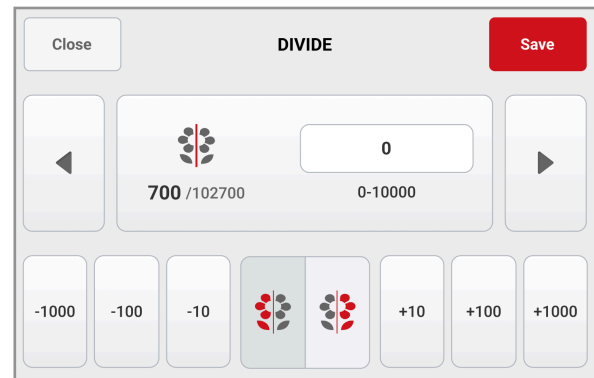

5 After adjustment, click 

6 Find 2 divided patterns in list.

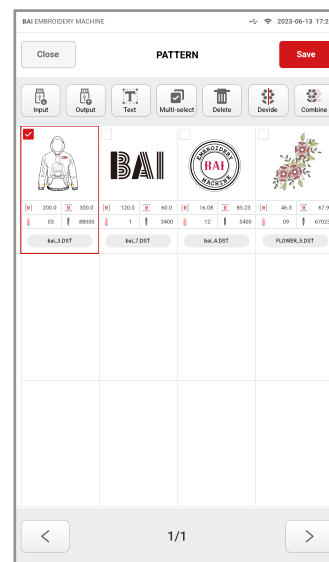

Tips:

- Design division is to divide the pattern into two according to the specified number of stitches. After the division, two divided designs will be displayed on the design management interface.
- The current version only supports dividing patterns by stitch sequence. If by outline, please use design software.

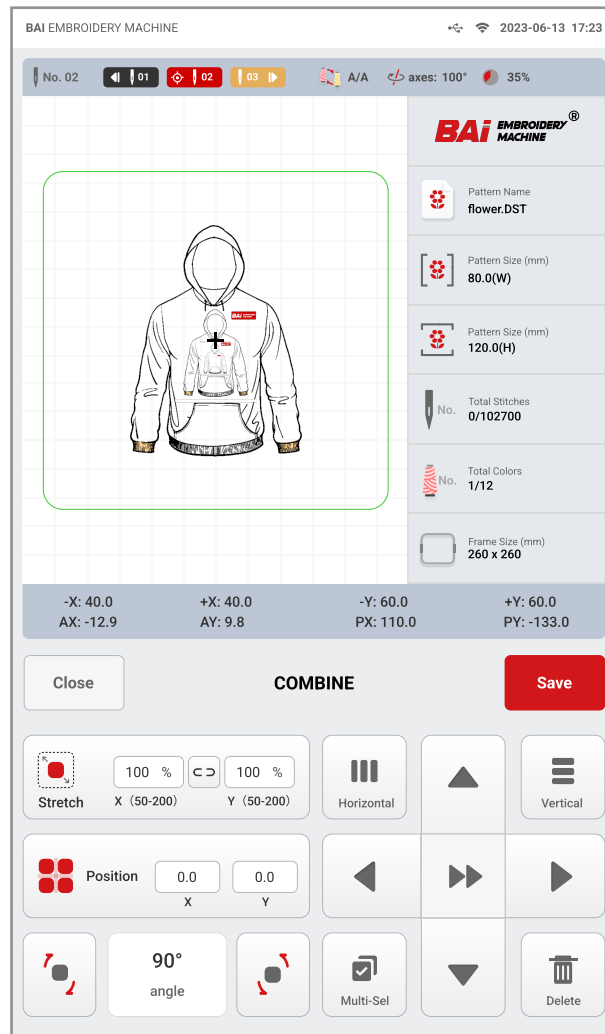

Contents

Description

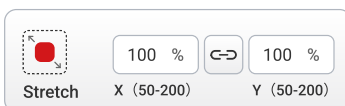









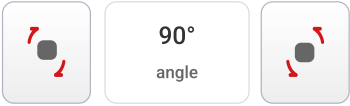

The scaling ratio of the pattern in X/Y direction.

- The default ratio is 100%, and the adjustable range is 50%-200%.
- It can zoom in and out in same proportion by clicking. 

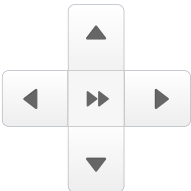

Adjust the X/Y direction spacing between patterns.

Contents	Description												
	<p>Pattern rotation setting.</p> <ul style="list-style-type: none"> • Tap to enter a custom rotation angle. •  Rotate according to the specified angle and direction: <table border="1" data-bbox="671 685 1425 1043"> <tr> <td>0° angle</td> <td>M0° angle</td> <td>Rotate 0 degrees/Mirror rotate 0 degrees.</td> </tr> <tr> <td>90° angle</td> <td>M90° angle</td> <td>Rotate 90 degrees/Mirror rotate 90 degrees.</td> </tr> <tr> <td>180° angle</td> <td>M180° angle</td> <td>Rotate 180 degrees/Mirror rotate 180 degrees.</td> </tr> <tr> <td>270° angle</td> <td>M270° angle</td> <td>Rotate 270 degrees/Mirror rotate 270 degrees.</td> </tr> </table> 	0° angle	M0° angle	Rotate 0 degrees/Mirror rotate 0 degrees.	90° angle	M90° angle	Rotate 90 degrees/Mirror rotate 90 degrees.	180° angle	M180° angle	Rotate 180 degrees/Mirror rotate 180 degrees.	270° angle	M270° angle	Rotate 270 degrees/Mirror rotate 270 degrees.
0° angle	M0° angle	Rotate 0 degrees/Mirror rotate 0 degrees.											
90° angle	M90° angle	Rotate 90 degrees/Mirror rotate 90 degrees.											
180° angle	M180° angle	Rotate 180 degrees/Mirror rotate 180 degrees.											
270° angle	M270° angle	Rotate 270 degrees/Mirror rotate 270 degrees.											
	<p>One-key horizontal arrangement of multiple patterns.</p> <ul style="list-style-type: none"> •  This function is arranged according to the origin point of the pattern, which may not be on the same horizontal line due to the different shape of the pattern. 												
	<p>One-key vertical arrangement of multiple patterns.</p> <ul style="list-style-type: none"> •  This function is arranged according to the origin point of the pattern, which may not be on the same vertical line due to the different shape of the pattern. 												
	<p>Switch between a single pattern and all patterns to edit.</p>												
	<p>Delete single or all patterns after selecting.</p>												
	<p>Move direction keys to adjust the distance between patterns.</p> <ul style="list-style-type: none"> •  It supports manual dragging to adjust the spacing between patterns, and a more precise position needs to be adjusted by inputting a value or moving direction. 												

 **Tips:**

- Directly use fingers to select specific patterns in the preview area.
- When a pattern is selected, its color displayed on the preview area, and the rest of the patterns are in gray.

How To Combine Patterns

1 Click 

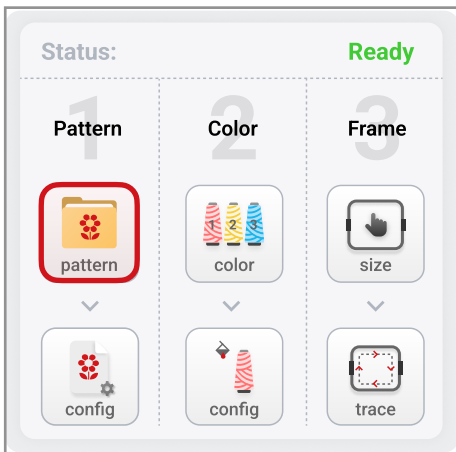

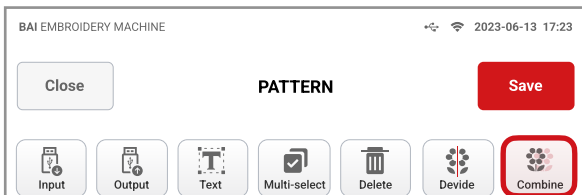

2 Click 

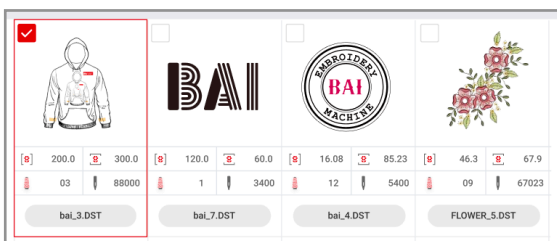

3 Select patterns to be combined.

i Up to 4 patterns can be selected for combination.



4 Click save after selection 

5 Combine patterns as request.

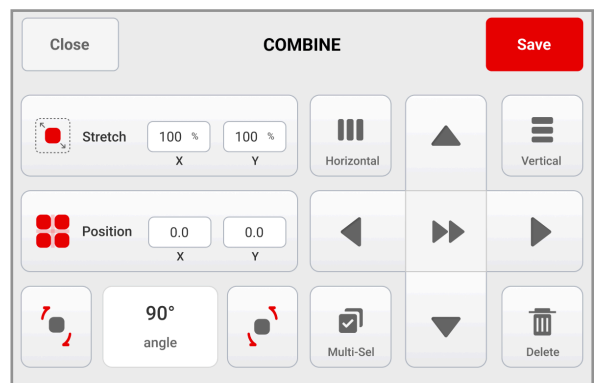

6 Click save After combination 

7 Combined patterns in pattern management list.

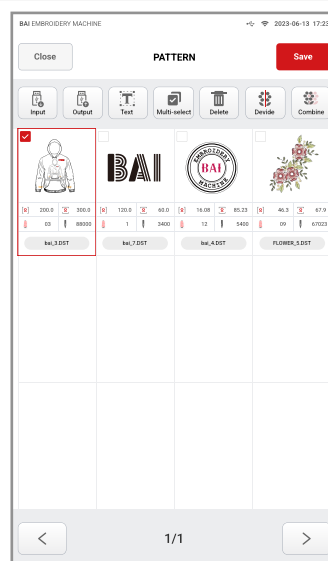

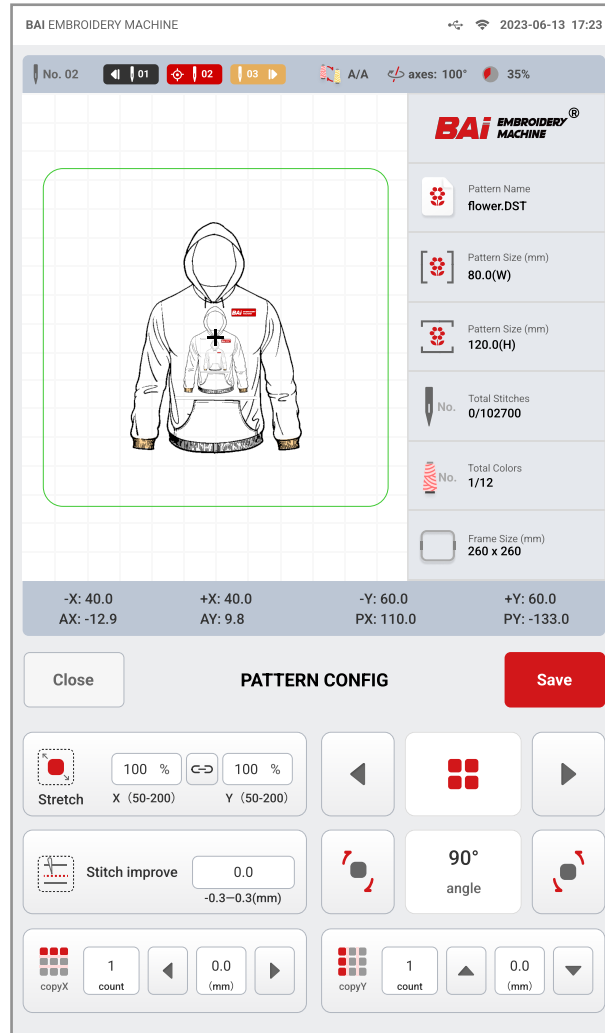

Contents

Description



The scaling ratio of the pattern in X/Y direction.

- The default ratio is 100%, and the adjustable range is 50%-200%.
- It can zoom in and out in same proportion by clicking. 

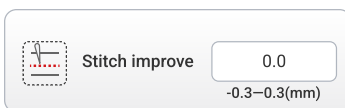

Stitch improve: Used to improve embroidery quality, according to different fabrics and patterns size to adjust.





- The default setting is 0mm. The more shrinkage of the fabric or the wider pattern, the bigger the stitch improve value will be set.
- Adjustable range -0.3 — 0.3mm.

Contents

Description



Symmetry mode: Switch between normal symmetry, X symmetry, Y symmetry, and XY symmetry.

- Normal symmetry: 
- X Symmetry: 
- Y Symmetry: 
- XY Symmetry: 

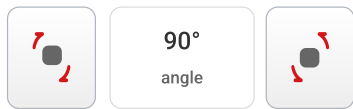

Pattern rotation setting.

- Tap to enter a custom rotation angle.

-  Rotate according to the specified angle and direction:

0° angle	M0° angle	Rotate 0 degrees/Mirror rotate 0 degrees.
-------------	--------------	---

90° angle	M90° angle	Rotate 90 degrees/Mirror rotate 90 degrees.
--------------	---------------	---

180° angle	M180° angle	Rotate 180 degrees/Mirror rotate 180 degrees.
---------------	----------------	---

270° angle	M270° angle	Rotate 270 degrees/Mirror rotate 270 degrees.
---------------	----------------	---

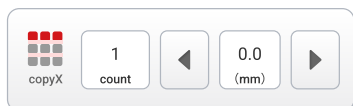

X-direction array editing.

- Click  to enter the desired number of arrays.

- Click  to adjust spacing of arrays.



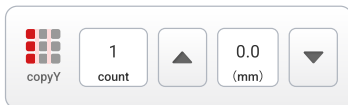

i The spacing is judged according to the origin point of embroidery, recommended that the spacing of the array be larger than that of the pattern's width.

Contents



Description

Y-direction array editing.

- Click  to enter the desired number of arrays.
- Click    to adjust spacing of arrays.
-  The spacing is judged according to the origin point of embroidery, recommended that the spacing of the array be larger than that of the pattern's height.

1 Click 

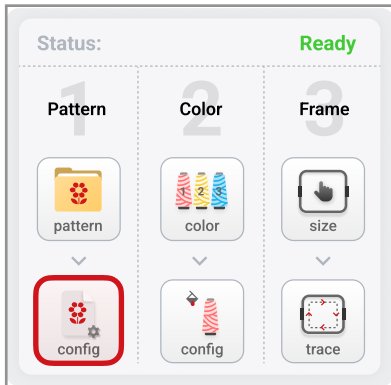

 Tips:

- Please use professional design software for more precise editing design request.

2 Edit patterns as needed.

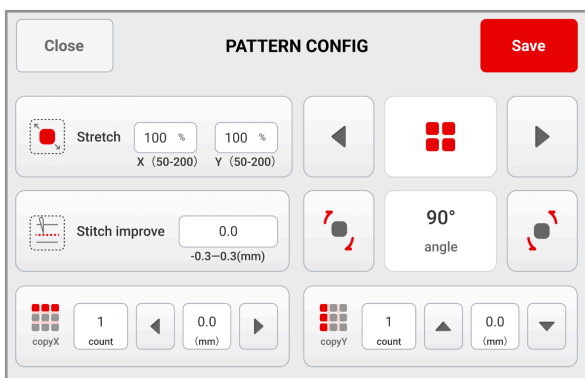

3 Click save after configuration 

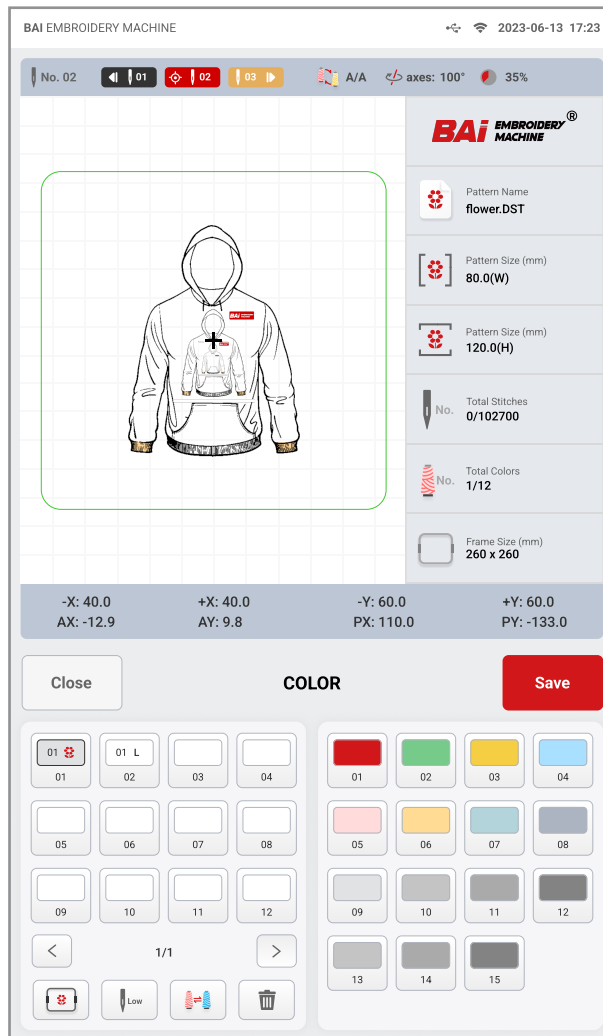

Color Settings Area

Needles Color Display Area

Contents

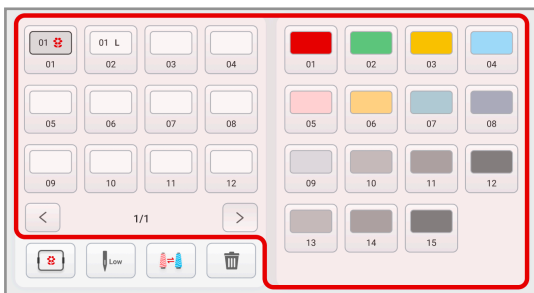







Description

On the left is the color sequence and total number of colors of the pattern.

On the right are the actual embroidery thread colors used for each needle.

- i If the color of the needle does not match the embroidery thread used, you can click Back to set the right color.
- ❖ Set needle bar number and thread color: P30
- i In the middle of setting, if the previous needle number is wrong, click selected and reset.

Contents	Description
	<p>Appliqué : If add appliqué in the current color, click this key, and the pattern will be added after the current needle number.</p>  <p>When embroider this color, it will automatically be out of the frame and stop, waiting for the appliqué to be added. After finishing, start the machine directly to continue embroidery.</p> <ul style="list-style-type: none"> • If want to cancel the appliqué, click it again.
	<p>Low-speed embroidery : If a certain color needs to be at a reduced speed, click this key, and "L" will be added after the current needle number.</p>  <p>When embroider this color, speed will be reduced to 400 spm.</p> <ul style="list-style-type: none"> • If cancel low-speed embroidery, click it again.
	<p>Modify colors in batches, click this key.</p> <p>At this time, the same colors will be selected, and then re-select the color in the needle color display area.</p> <ul style="list-style-type: none"> • If cancel the batch modification of colors, click it again.
	<p>Delete : Deletes the incorrect needle number midway through setup.</p> <ol style="list-style-type: none"> 1.Click incorrect needle number. 2.Click the delete icon. 3.Click OK to clear the subsequent color sequence.

How To Set Colors

1 Confirm the total number of colors in the pattern.

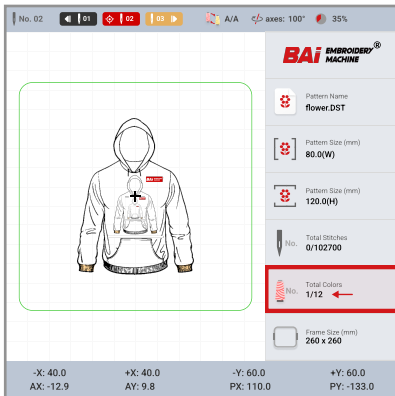

2 Click 

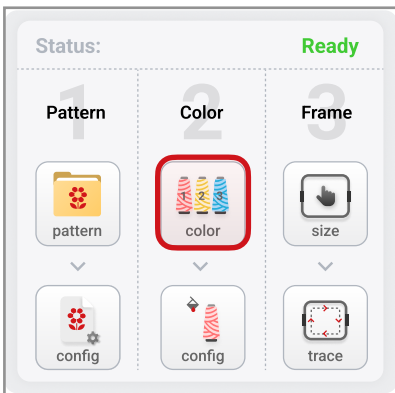

3 Click

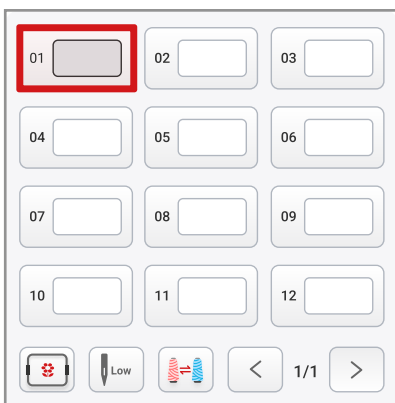

i Tips :

- Take figure 1 as an example, the pattern has 12 colors, then you need to set from 01 to the 12th color.

4 Select the corresponding needle number according to the color.



5 Click save after setting 

i tips:

- This machine supports up to 200 total colors.
- If the previous color is wrong in the middle of setting, please re-select and set.

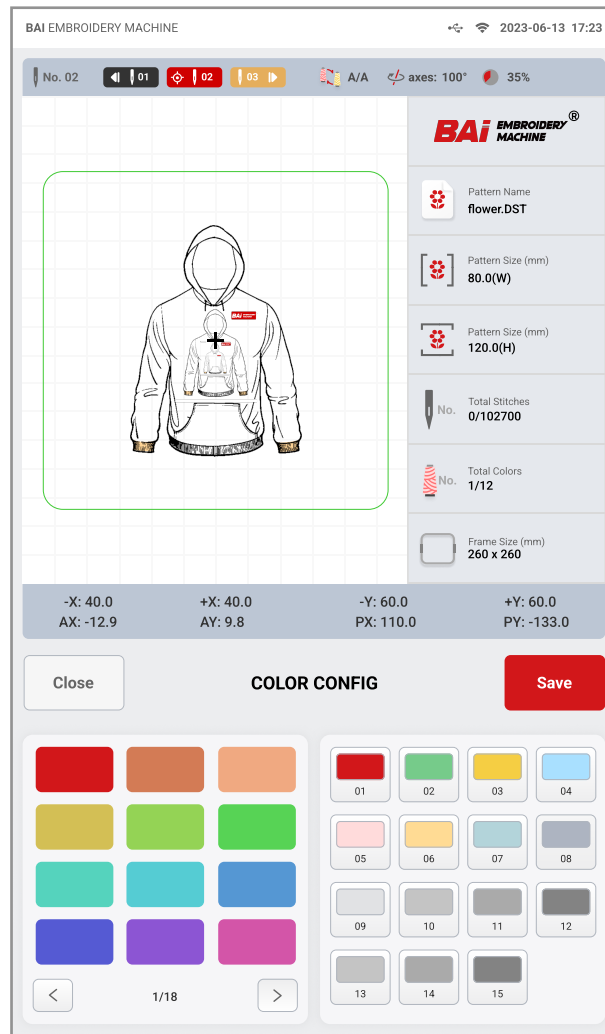

Contents

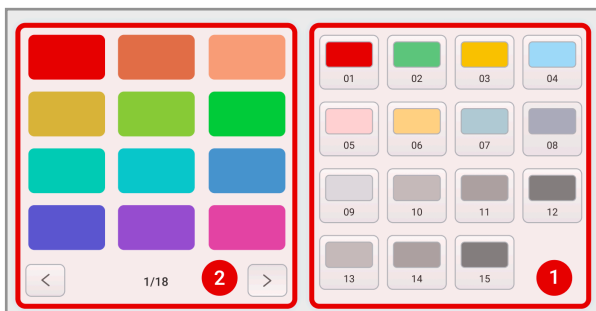

Description

1. First select the needle number to be set.
 2. Click the color block on the left to select the desired color, and click Save.
- i** Please refer to the actual color of the embroidery thread corresponding to the needle.

How To Set Needle Colors

1 Click 

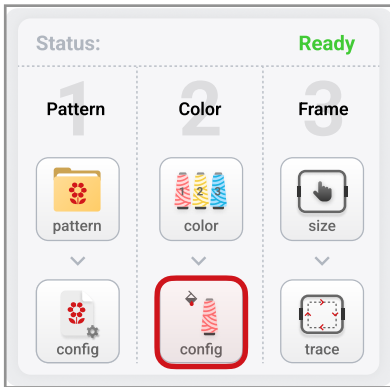

3 Select the color of the blocks as desired.



2 Click the needle number to be set.



4 Click Save after setting 

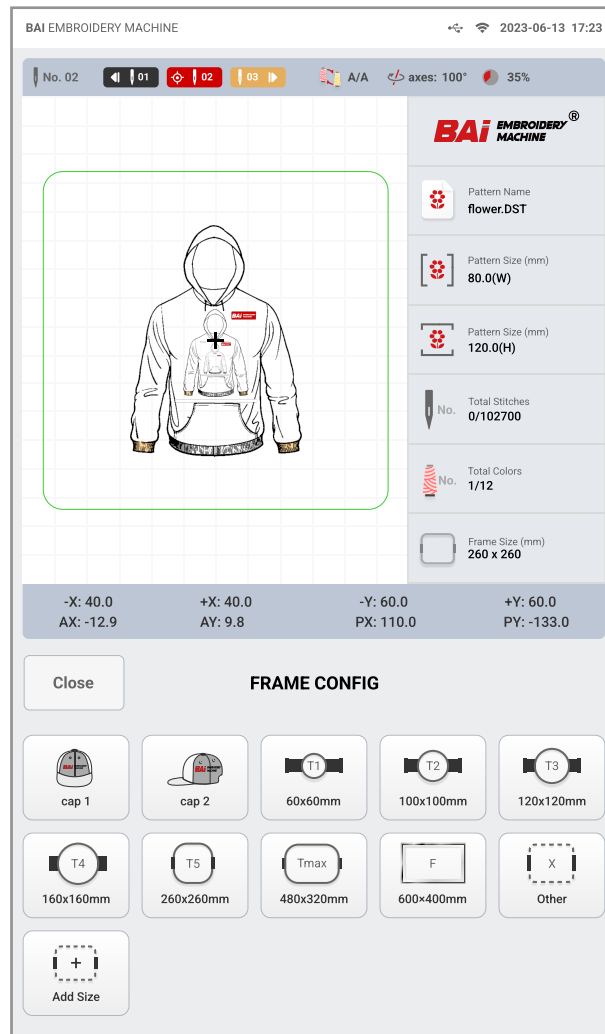

Contents

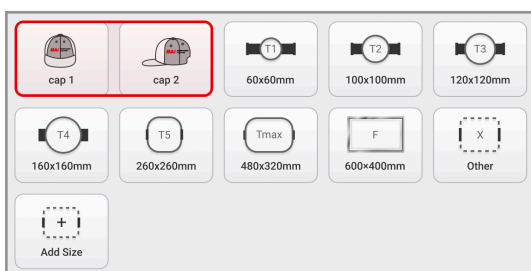

Description

Cap1: For front part of cap.

Cap2: For side and back part of cap.



Must first select the hat frame, and then install the hat driver when embroider cap!

内容

描述

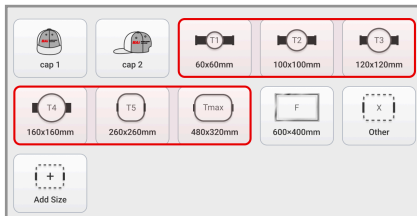

T1-TMax : Garments hoops.

- T1: 60*60mm/2.4"* 2.4"
- T2: 100*100mm/3.9"* 3.9"
- T3: 120*120mm/4.7"* 4.7"
- T4: 160*160mm/6.3"* 6.3"
- T5: 260*260mm/10.2"* 10.2"
- Tmax: 480*320mm/18.9"* 12.6"

i Please refer to the actual configuration size of different models for the maximum size of the frame.

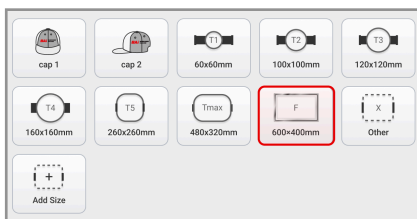

F : Flat embroidery frame. Aluminum material, used with the table board, often used in flat embroidery.

- F: 600*400mm/23.6"* 15.7"

i For details, refer to the actual configuration size of different models.

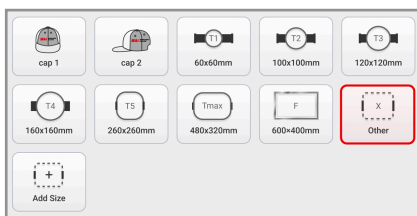

Other : any size.

This embroidery frame can be used when frame is not within the selection range of T1-T5.

i The frame has no boundaries, please use tracking positioning to determine the embroidery position before starting embroidery.

❖ tracking and positioning: P36

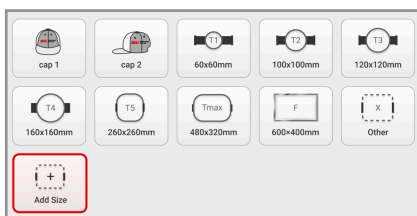

Quickly add embroidery frames.

- When choose other size frame, quickly add the frame to the machine.
- Add up to 5 different frame types.



When choosing an embroidery frame, be sure to uninstall the cap drive to prevent collisions!

i tips:

- Select a suitable embroidery frame according to the size of the pattern, and frame size bigger than actual embroidery size.
- If the selected embroidery frame is too large, the frame will be too loose and affect embroidery quality.
- After the cap frame is selected, the currently selected pattern is automatically rotated 180, other frame remain the same.

Quickly Add Embroidery Frames

1 Install hoops in machine.

2 Click size key 

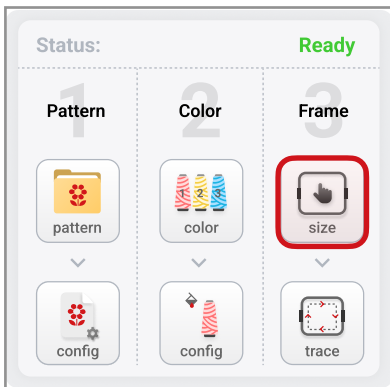



3 Click add size key.

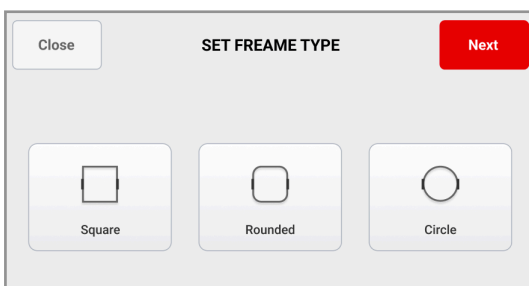

4 Click the type of embroidery frame to be added.

i Select according to the actual frame type.



5 Click save after setting 

6 Click OK.

7 Find the left edge of frame.

- Move the direction key to make the No. 1 needle close to the left edge.
- After confirming the left edge, click Next.
- i* Please pay attention to the control distance (needle No. 1 presser foot is far away from the inside of the embroidery frame about 1 cm), can't touch the embroidery inside edge.

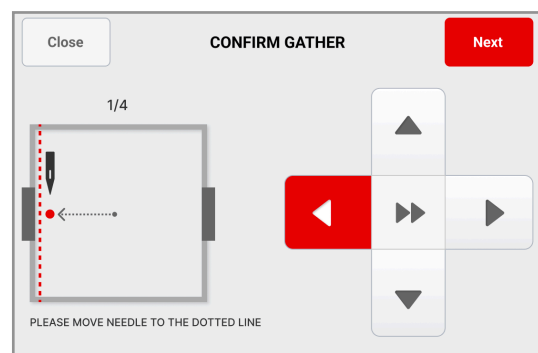

8 Find the top edge of frame.

- Move the direction key to make the No. 1 needle close to the top edge.
- After confirming the top edge, click Next.
- i* Please pay attention to the control distance (needle No. 1 presser foot is far away from the inside of the embroidery frame about 1 cm), can't touch the embroidery inside edge.

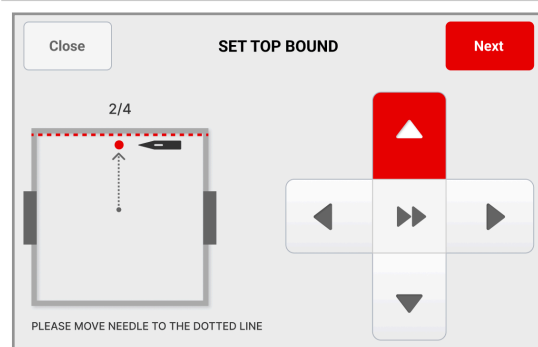

Quickly Add Embroidery Frames

9 Find the right edge of frame.

- Move the direction key to make the No. 1 needle close to the right edge.
- After confirming the right edge, click Next.
- i** Please pay attention to the control distance (needle No. 1 presser foot is far away from the inside of the embroidery frame about 1 cm), can't touch the embroidery inside edge.

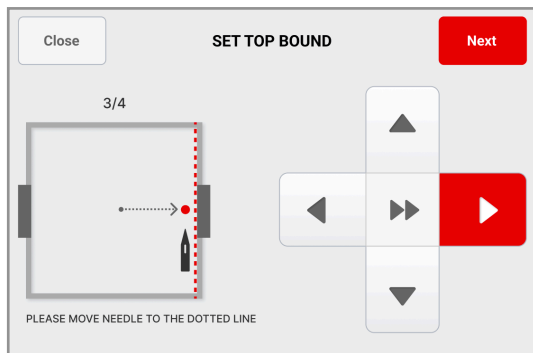

10 Find the bottom edge of frame.

- Move the direction key to make the No. 1 needle close to the bottom edge.
- After confirming the bottom edge, click Next.
- i** Please pay attention to the control distance (needle No. 1 presser foot is far away from the inside of the embroidery frame about 1 cm), can't touch the embroidery inside edge.

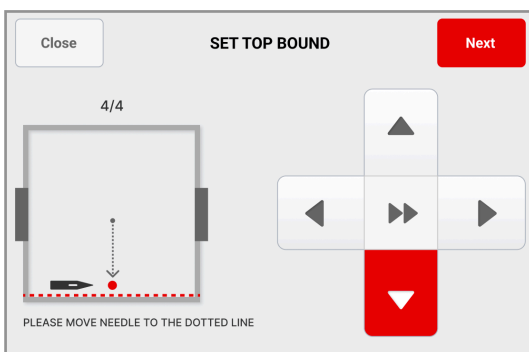

11 If confirm to add, click **Confirm**

If the data collection is wrong, click Close to re-collect.

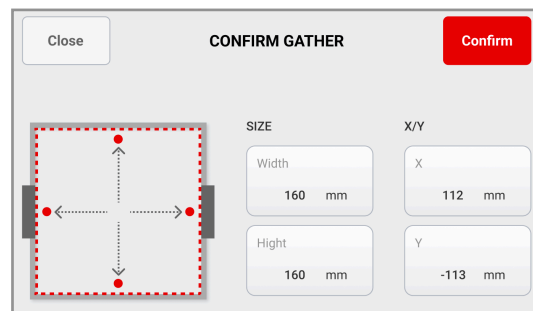

12 The new frame will be displayed in the list.

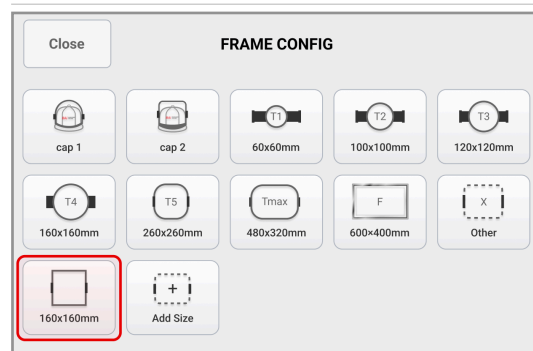

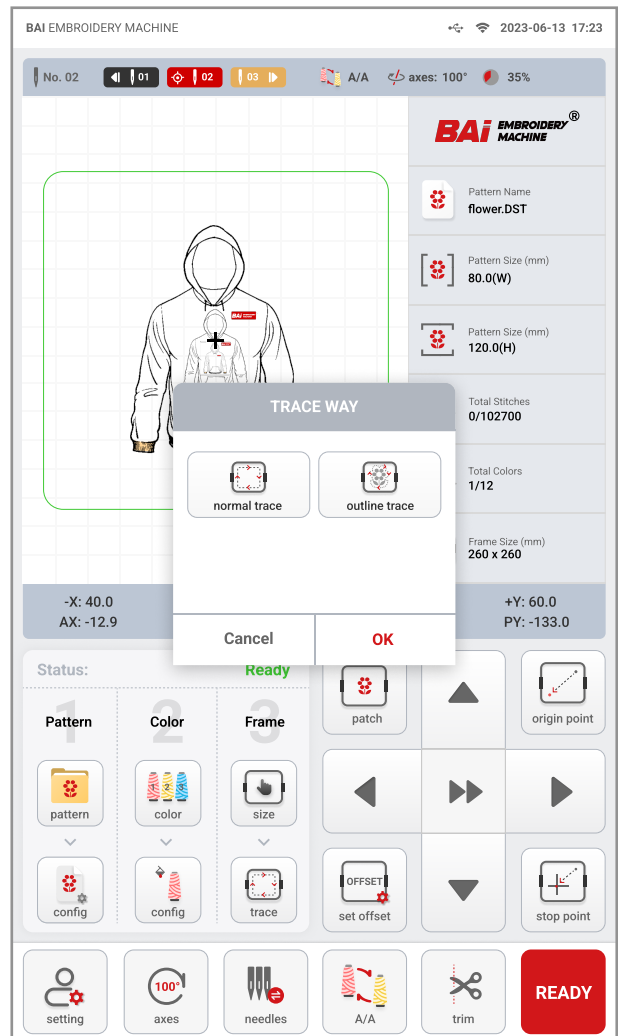
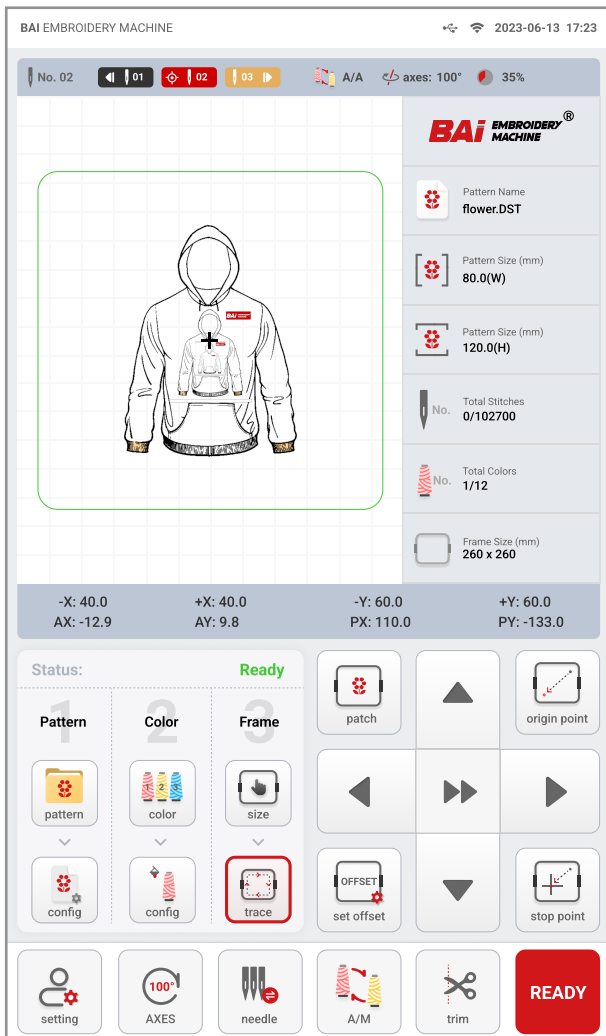

Contents

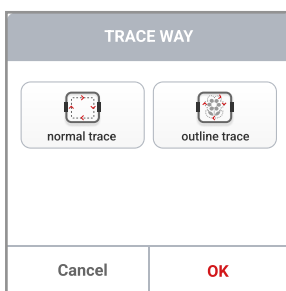

Description

Before embroidery, it is used to confirm the embroidery position of the pattern.

- The pattern cannot exceed the embroidery frame.
- **i** Used with laser positioning, if there is no such device, you can observe the contour area that needle No. 1 walks through.

内容

描述

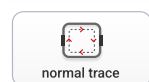

Normal trace: Fast tracking along the largest edge of the pattern.

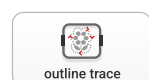

Outline trace: Stitch tracking on the actual edge of the pattern.

- Normal trace first, then outline trace



Before embroidery, be sure to track and position to avoid frame collision during embroidery!



When no laser positioning device, it is forbidden to press the No. 1 needle by finger for tracking, so as to avoid collision on frame personal injury and machine damage!

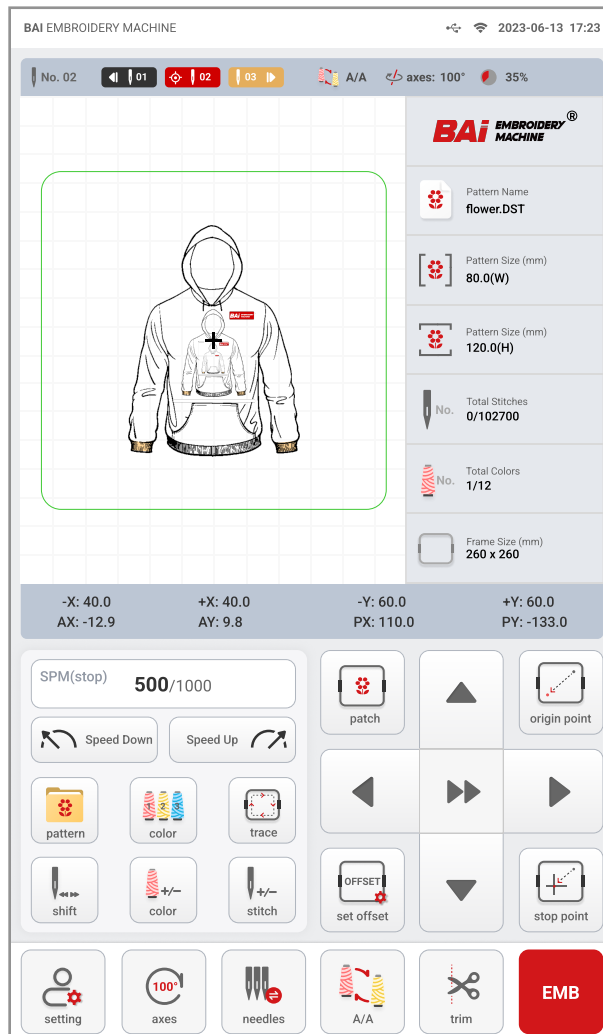

Contents

Description







SPM(stop) **500**/1000

Working status display area (waiting, embroidery, thread breakage, completion)

Embroidery speed display: Real-time speed/maximum speed set.

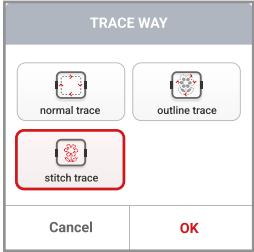
Speed Down Speed Up

Speed down / Speed up.

内容	描述
 <p>pattern</p>	<p>Operations such as pattern selection, input, output, division, combination, and deletion.</p> <ul style="list-style-type: none"> • Same as Ready state. <p>❖ Detailed introduction: P10</p>
 <p>color</p>	<p>Set the color of the pattern.</p> <ul style="list-style-type: none"> • Same as Ready state. <p>❖ Detailed introduction: P27</p>
 <p>trace</p> 	<p>Embroidery status trace and position: add stitch trace embroidery mode.</p> <p>i When entering the stitch embroidery mode, normal trace must be performed first to avoid frame collision.</p>
 <p>shift</p>	<p>Forward/Backward at high/low speed.</p>
 <p>color</p>	<p>Forward/Backward by color.</p>
 <p>stitch</p>	<p>Forward/Backward by stitches.</p>



Before embroidery, be sure to trace and position to avoid frame collision during embroidery!



All forward and backward operations must be at stopped state, can't during machine running!

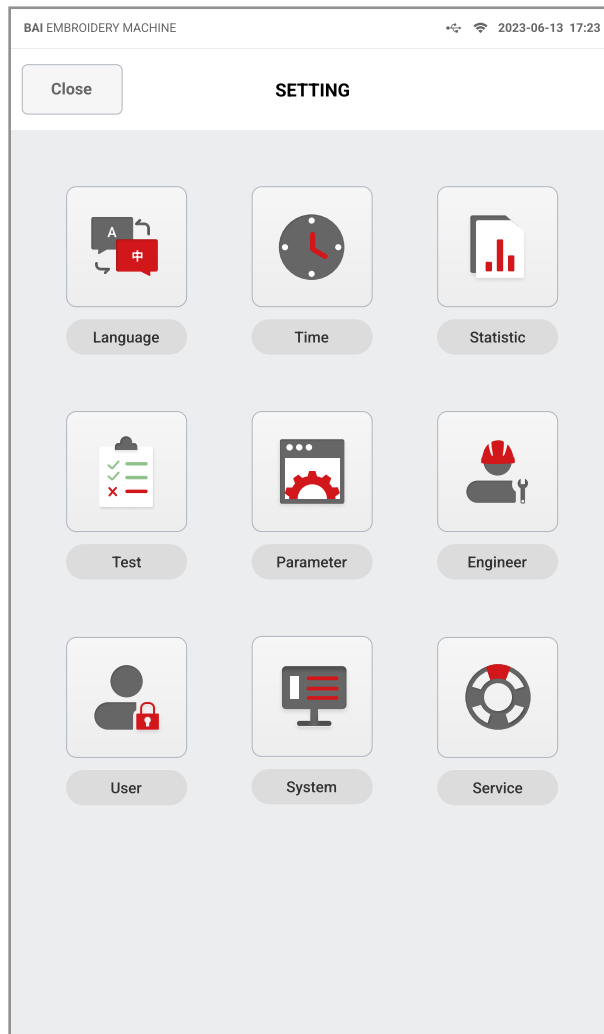

Contents







Description



Language : Set the machine language.



Time : Set the machine time.

内容	描述
	Statistics : Used to view working statistics and clear statistics operations.
	Test : Used to test whether the sensors, motors, and control boards of the machine are functioning normally.
	Machine parameters : Used to set machine thread trimming, thread breaking, speed, embroidery frame and other related parameters.
	Engineer parameters : Used under the guidance of professional technicians, please do not modify it without authorization, prevent machine malfunction.
	User : Used to connect to Wifi, find the origin. power-off recovery so more operation.
	System : Used to view system information, software upgrade, input and output of parameters and other operations.
	Service : If you have any usage questions, you can contact us through the contact information on the service page.

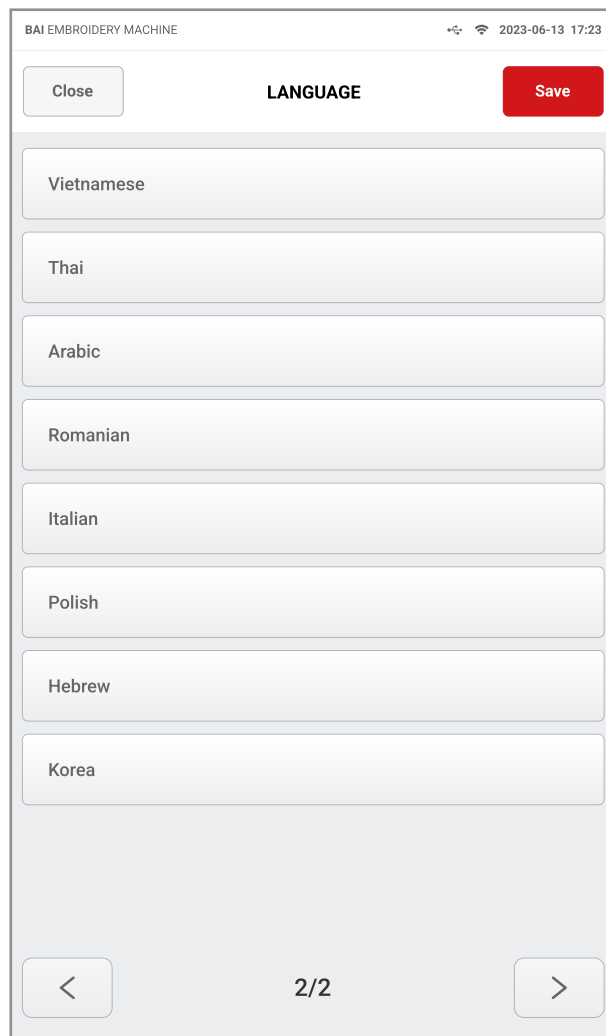
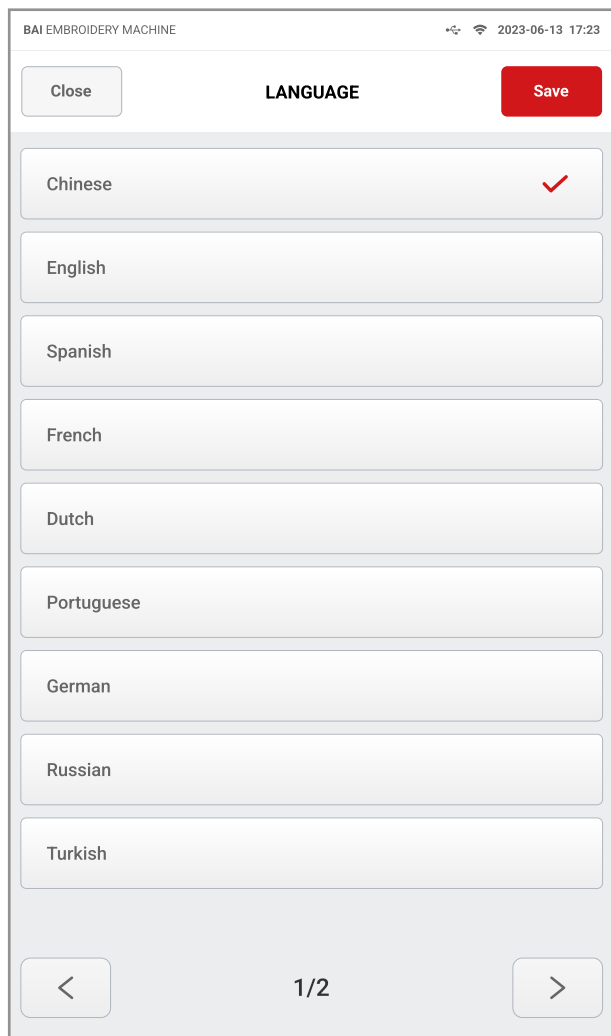

Description

The machine supports 17 languages and can be modified as needed.

BAI EMBROIDERY MACHINE 2023-06-13 17:23

Close TIME Save

Year 2021

Month 3

Day 21

Hour 12

Minute 6

Description

Set machine time.

BAI EMBROIDERY MACHINE 2023-06-13 17:23

Close **STATISTIC**

Total Startup Time 12:35:06

Total Stitches 16582

Total Thread Trimming Times 6

Pattern No	Pattern Name	Embroidery Sum	Total Completed	Break Times	Operate
1	dh_01	4534	5	3	
2	dh_33	15264	2	18	
3	dh_01	4534	5	128	
4	dh_33	15264	2	18	
5	dh_01	4534	5	128	
6	dh_33	15264	2	18	
7	dh_01	4534	5	138	
8	dh_33	15264	2	182	
9	dh_01	4534	5	118	
10	dh_33	15264	2	178	

1/2

Description

- List data can be cleared by clicking 
- The total data cannot be deleted or changed, and normal test data displayed after the new machine is received.

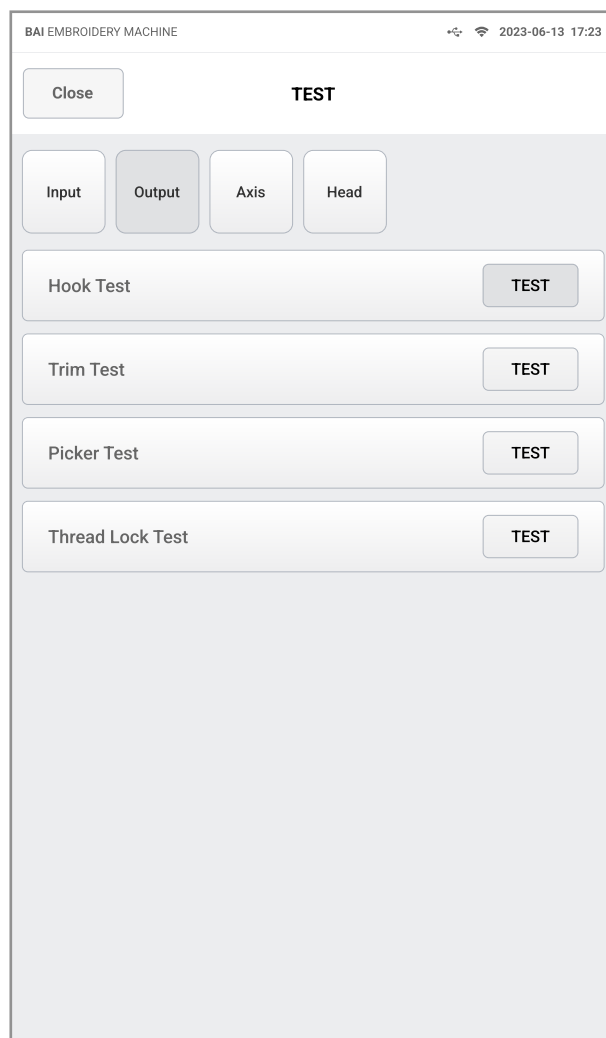
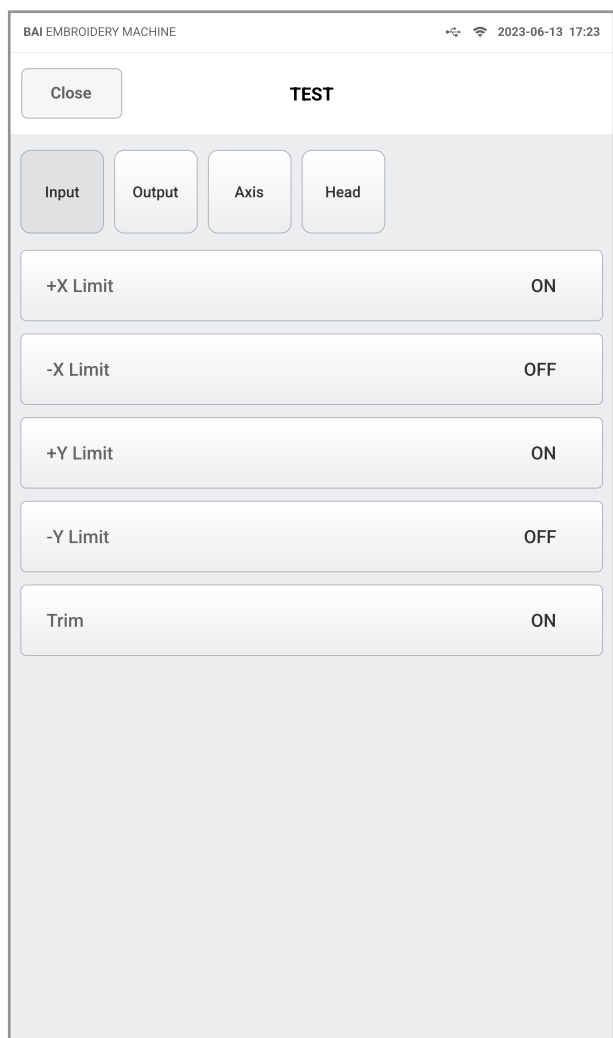

Contents



Description

Input signal test.

Test whether the X-axis, Y-axis sensor signals, trimming sensor signals are normal.

Output signal test.

Click test to test whether the thread hooking, trimming, picking, and upper thread clamping are normal.

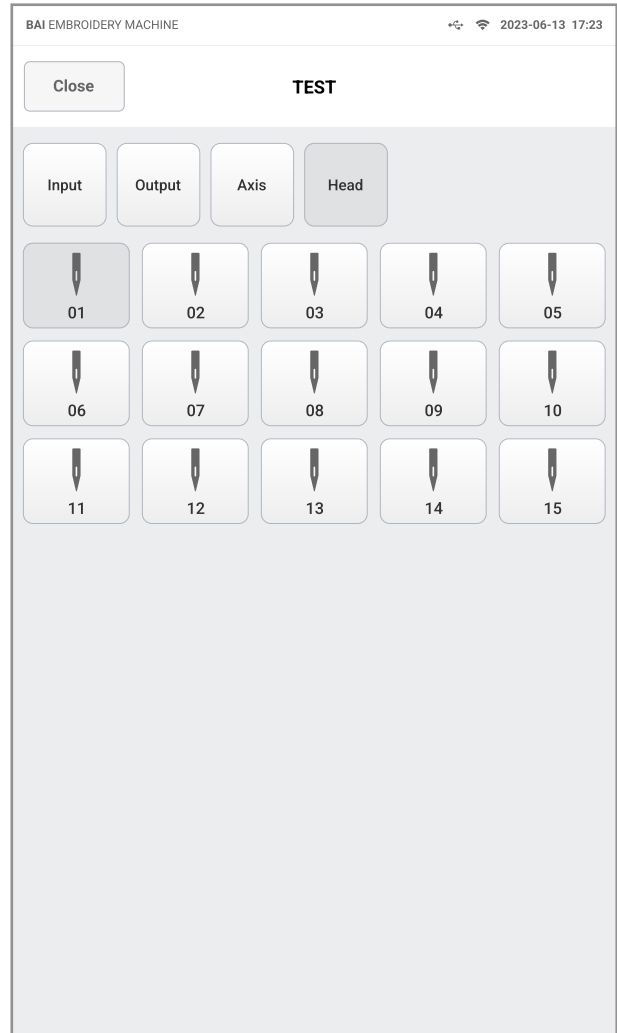
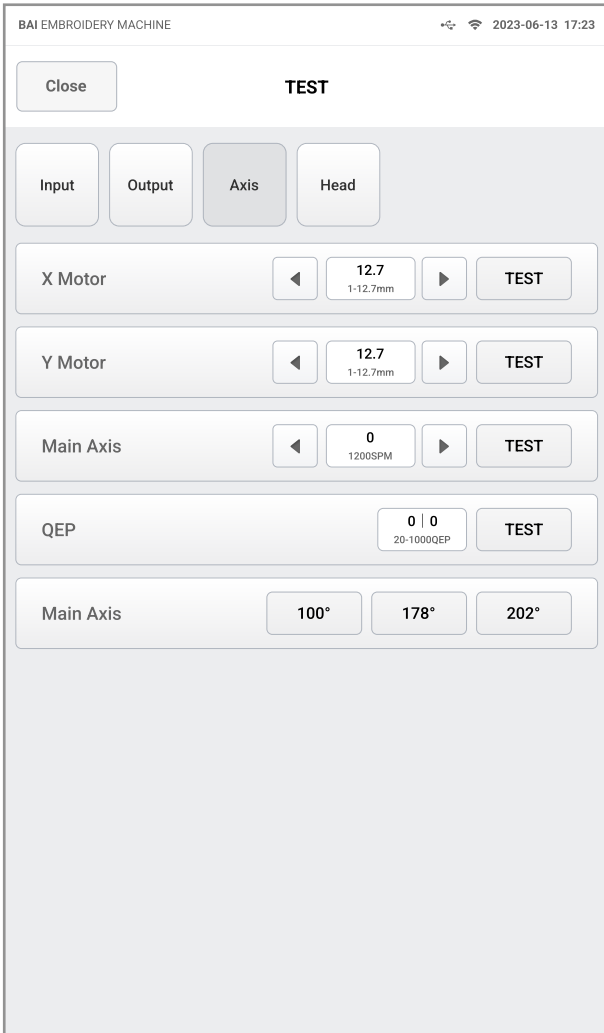

Contents

Description



Axis test: Test whether the X-axis motor, Y-axis motor, main axis motor, and zero optocoupler are normal.

- Main axis 100 degrees: Click the main axis to turn to 100 degrees.
- Main axis 178 degrees: Click the main axis to turn to 178 degrees.
- Main axis 202 degrees: Click the main axis to turn to 202 degrees.



Head test.

- Used to detect whether the thread breakage detection optocoupler is normal.

How To Test Machine Head's Board

47



4 Click the needle bar number to be detected.

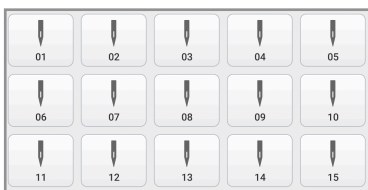

5 Use your fingers to turn the roller of corresponding needle.

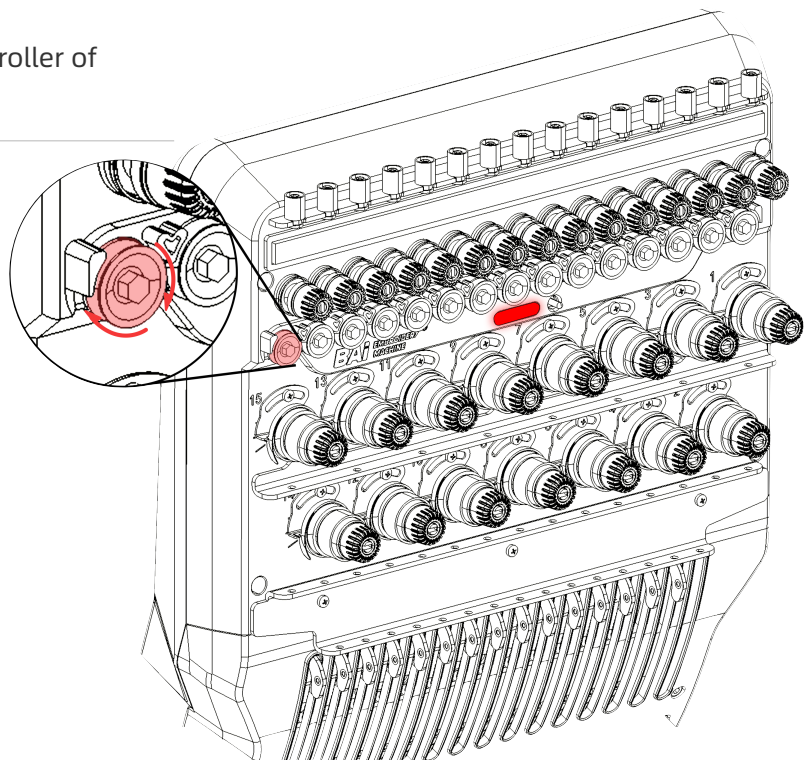

6 Observe the central indicator light, if red and flashes with the rotation of the roller, it means that the roller inspection optocoupler is normal.

i If the color of the red alarm indicator remains unchanged, it means that the roller detection optocoupler is abnormal.

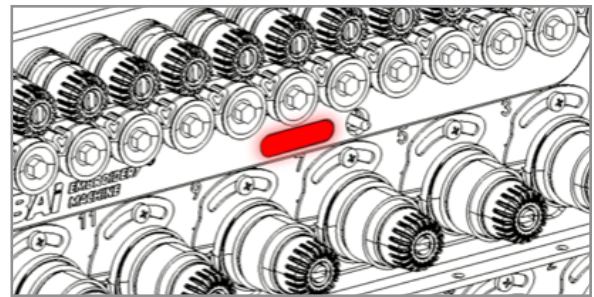

- 7 Toggle down the spring by hand to separate spring and iron piece.

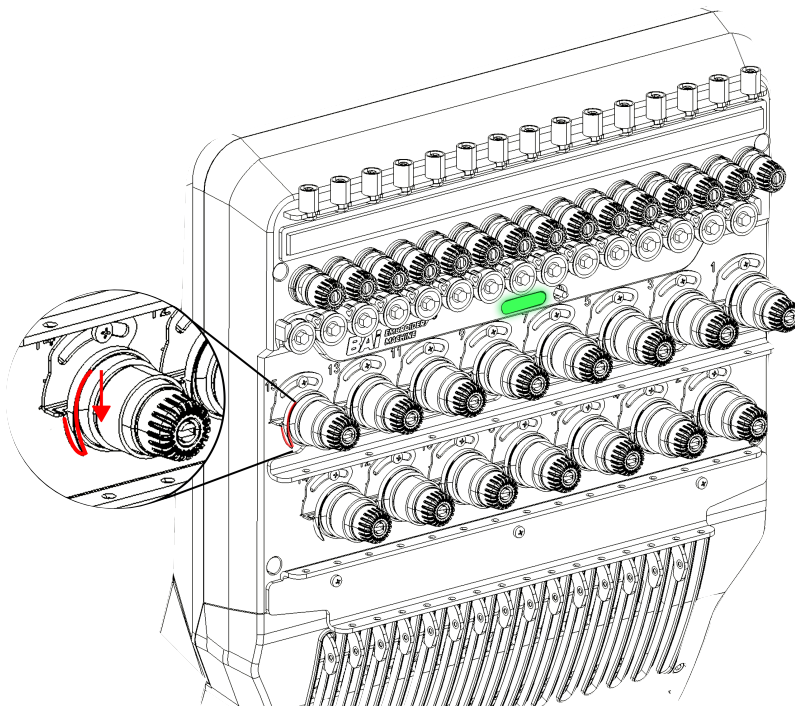

- 8 Observe the indicator light in the center, after the spring is separated from the iron piece indicator light changes from red to green, it means that the spring detection optocoupler is normal.

i If the red alarm indicator remains the same, it means that the spring detection optocoupler is abnormal.

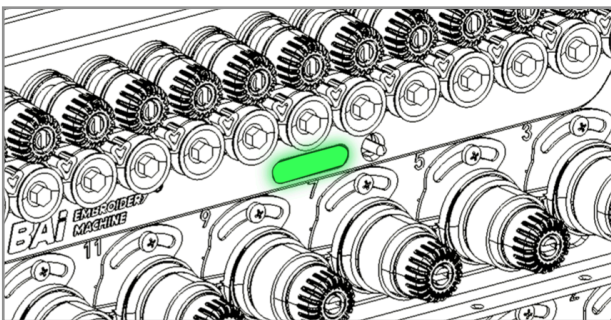

BAI EMBROIDERY MACHINE 2023-06-13 17:23

Close PARAMETER Save

Set Trim Broken Speed Frame

Auto Set Start Point ◀ Yes ▶

Auto Return Start Point ◀ Yes ▶

Auto Return Offset ◀ No ▶

Same Color Auto Start ◀ Yes ▶

Back To Stop Point ◀ No ▶

Finish Beep ◀ Off ▶

Positioning Red Light Mode ◀ Auto ▶

Stop Frame Of Moving ◀ Yes ▶

< 1/3 >

BAI EMBROIDERY MACHINE 2023-06-13 17:23

Close PARAMETER Save

Set Trim Broken Speed Frame

Auto Jump Stitches ◀ 6.5mm ▶

Choose EMB Type ◀ Slow ▶

Repeat Embroidery ◀ No ▶

Thick Material Embroidery ◀ Off ▶

Needles NO. ◀ 15 ▶

Hole Needle Position ◀ 0 ▶

Make Up Stitch ◀ 0 ▶

Make Up Method ◀ Single ▶

< 2/3 >

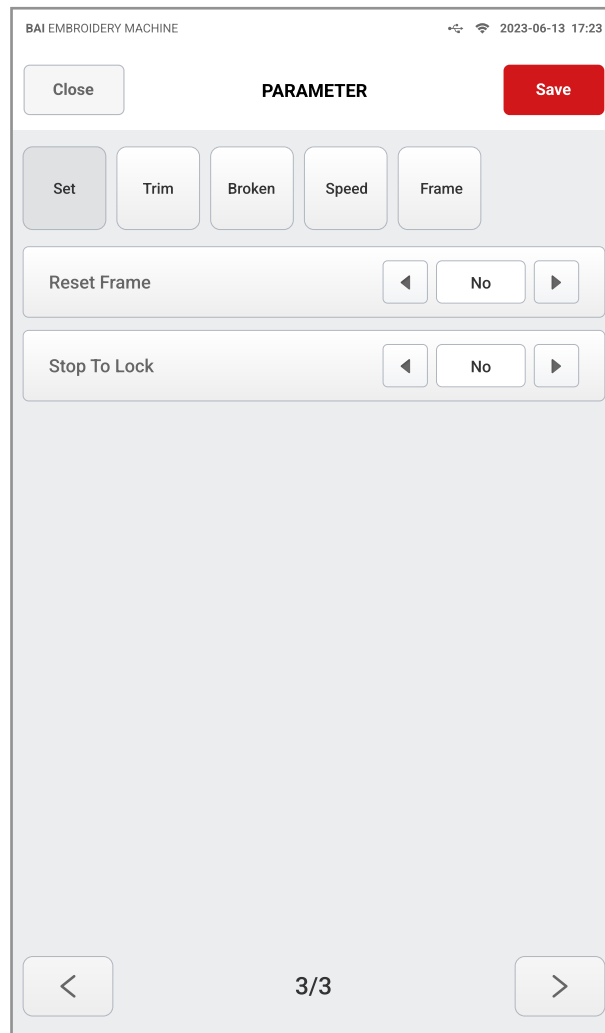

Parameter Name	Parameter Description	Defaults
Auto Set Start Point	When set pattern beginning to end continuous embroidery : <ul style="list-style-type: none"> • If set yes, pattern will embroidery from former stop point. • If set no, pattern will embroidery from the whole origin point. 	Yes

Parameter Name	Parameter Description	Defaults
Auto Return Start Point	<p>Whether return to start point after finished:</p> <ul style="list-style-type: none"> • If set yes, it will return to start point after finish. • If set no, it will stop at the last one stitch point after finish. 	Yes
Auto Return Offset	<p>Whether the frame automatically shift to the top of the frame after the embroidery is finished. (The parameters of the embroidery frame must correspond to the size of the embroidery frame)</p>	No
Same Color Auto Start	<p>Whether to auto start 2 adjacent same color.</p> <ul style="list-style-type: none"> • If set yes, adjacent 2 same color will start automatically. • If set no, 2 adjacent same color , after first one finished ,machine will stop, need to start 2rd color manually. 	Yes
Back To Stop Point	<p>Whether return to stop point when frame move halfway.</p> <ul style="list-style-type: none"> • If it is set to "Yes", it will. • If it is set to "No", it will not. 	No
Finish Beep	<p>Whether to turn on the beep after embroidery is completed.</p> <ul style="list-style-type: none"> • If set to "Yes", there will be a beep. • If set to "No", there will be no beep. 	Yes
Positioning Red Light Mode	<p>The red light positioning mode is turned on during tracing.</p> <ul style="list-style-type: none"> • If set to "Auto", the red light positioning will be turned on automatically when tracking and the red light positioning is off for other operations. • If set to "Constant Light", the red light will always be on after power on. • If it is set to "OFF", the red light positioning will be turn off under any operation. 	Auto
Stop Frame Of Moving	<p>Whether to pull the key to stop when crossing the frame.</p> <ul style="list-style-type: none"> • If set to "Yes", click key will stop. • If it is set to "No", click key will not stop. 	Yes
Auto Jump Stitches	<p>When long-step embroidery is jumping, when the stitch step length exceeds a certain value, it will be automatically divided into two or more stitches for embroidery.</p>	6.5mm
Choose Emb Type	<p>Which method to use for long-step stitch embroidery.</p> <ul style="list-style-type: none"> • The default setting is "Slow" except for embroidered hats. • Set to "Jump"when embroider caps. 	Slow

Parameter Name	Parameter Description	Defaults
Repeat Embroidery	<p>Whether to repeat embroidery automatically after the pattern is completed.</p> <ul style="list-style-type: none"> • If set to "Yes", the embroidery will be repeated. • If Set to "No", the machine will stop. 	No
Thick Material Embroidery	<p>Whether to choose embroidery thick material.</p> <ul style="list-style-type: none"> • If set to "Yes", the embroidery speed will be reduced. • If it is set to "No", the embroidery speed will not be reduced. 	No
Needles No.	<p>The number of needle currently used by the embroidery machine. If the current machine uses 15 needles, set the parameter to "15".</p>	15
Hole Needle Position	<p>The Hole Needle Position is the needle number used when eyelet embroidery, and you need to set this value to the corresponding needle position.</p> <ul style="list-style-type: none"> • This needle position does have thread breakage detection during embroidery. • When hole needle embroidery is not required, set to "0". 	0
Make Up Stitch	<p>How many stitches set in advance when make up is almost finished, ask the rest of the non-make up machine heads embroider together.</p>	0
Make Up Method	<p>When Embroidering, Whether All-Head Or Single-Head Make Up.</p> <ul style="list-style-type: none"> • If set to "All Heads", all heads will stitch during make up. • If set to "single head", only the thread-broken machine head will stitch for making up. 	Single
Reset Frame	<p>Whether to find the absolute origin of the embroidery frame when power on.</p> <ul style="list-style-type: none"> • If set to "Yes", every time the power on, the embroidery frame will be reset, and the frame will automatically return to the stop position before power off. • If set to "No", it will not return to the stop position before power off when the power on. 	No
Stop To Lock	<p>Whether to lock the axis in stop state.</p> <ul style="list-style-type: none"> • If set to "Yes", the main axis will not be locked in stop state. • If set to "No", the main axis will be locked in stop state. 	No

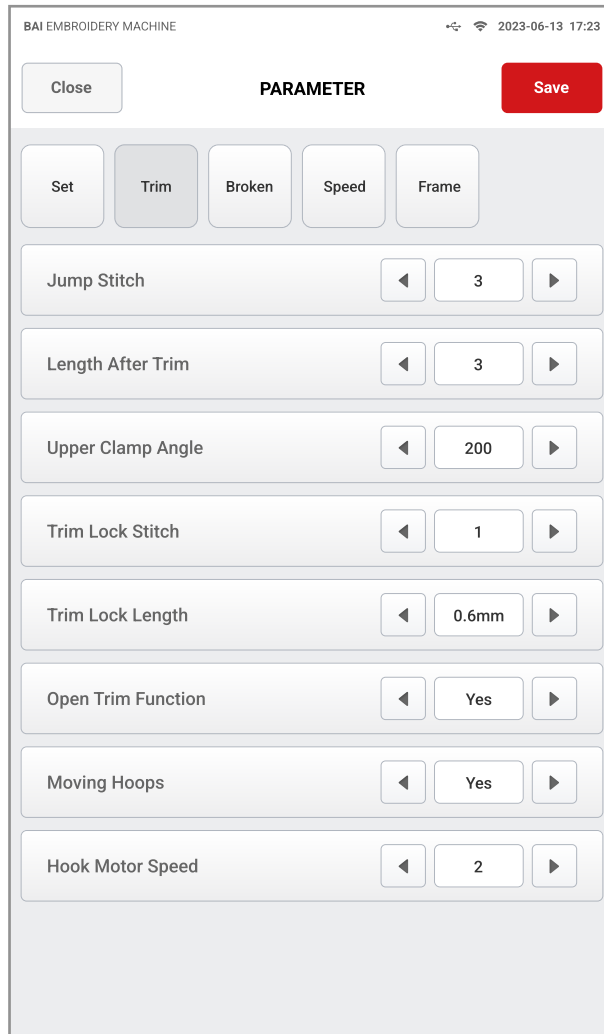

Parameter Name	Parameter Description	Defaults
Jump Stitch	Amount of jump stitches start trimming or no trimming, the larger the value is, the thread trimming less frequent.	3
Length After Trim	The remaining length of upper thread after thread trimming, the larger the number, the longer the remaining thread.	3
Upper Clamp Angle	The angle at which the upper thread clamp opens after it is closed again after startup. The larger the value, the later the angle at which the upper thread clamp closes and opens.	200

Parameter Name	Parameter Description	Defaults
Trim Lock Stitch	How many stitches are locked during thread trimming and starting to prevent the thread from falling off after thread trimming, value The larger the value , the more trim lock stitches during thread trimming and starting.	1
Trim Lock Length	When embroidering thin materials, the length of the lock stitch should be large, and when embroidering thick materials, it should be appropriately reduced.	0.6mm
Open Trim Function	Whether to Open Trim Function. <ul style="list-style-type: none">• When set to "Yes", the machine uses the thread trimming function.• When set to "No", the machine does not use the thread trimming function.	Yes
Move Hoops	Whether to move hoops after thread trimming. <ul style="list-style-type: none">• If set to "Yes", the embroidery frame will move when thread trimming.• If set to "No", the embroidery frame will not move when thread trimming.	Yes
Hook Motor Speed	The speed when using the hook motor the larger the value, the faster the speed.	2

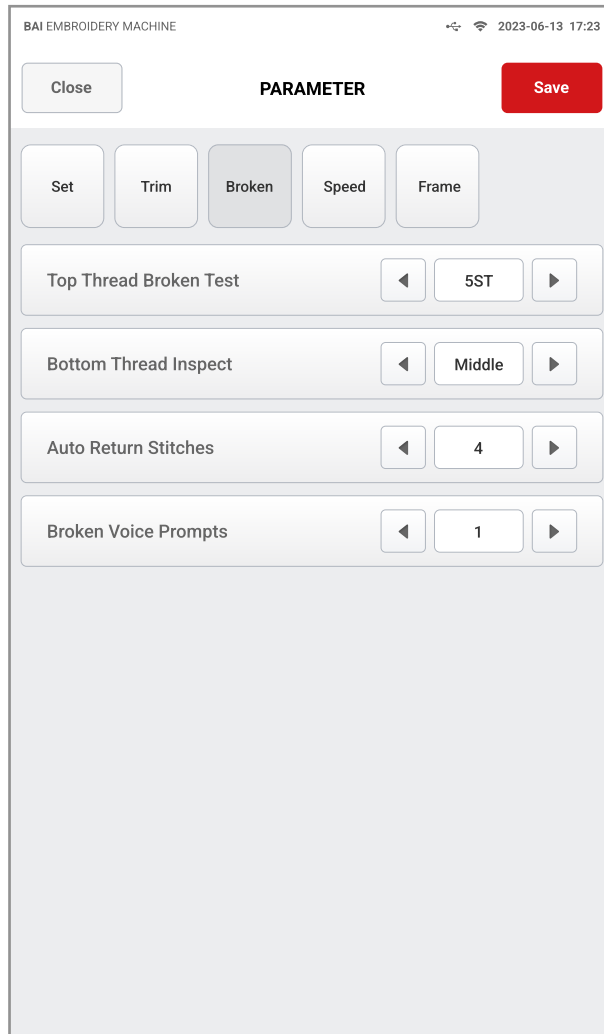

Parameter Name	Parameter Description	Defaults
Top Thread Broken Test	<p>Upper thread breakage detection sensitivity.</p> <ul style="list-style-type: none"> The larger the value set, the lower the detection sensitivity. If set to "no detection", it will not alarm and stop after thread breakage. 	5St

Parameter Name	Parameter Description	Defaults
Bottom Thread Inspect	<p>Bottom thread broken detection sensitivity.</p> <ul style="list-style-type: none">• When set to "High", the detection sensitivity is high.• When set to Medium, the detection sensitivity is medium.• When set to "no detection", it will not alarm and stop after thread breakage.	Middle
Auto Return Stitches	<p>Automatic turn stitches after thread breakage, based on detection.</p> <ul style="list-style-type: none">• The larger the value, the more stitches will be automatically returned.	4
Broken Voice Prompts	<p>How often is the prompt after thread breakage.</p> <ul style="list-style-type: none">• The smaller the value is, the shorter the thread breakage beep interval will be.• If set to "OFF", there will be no prompt sound after thread breakage.	1

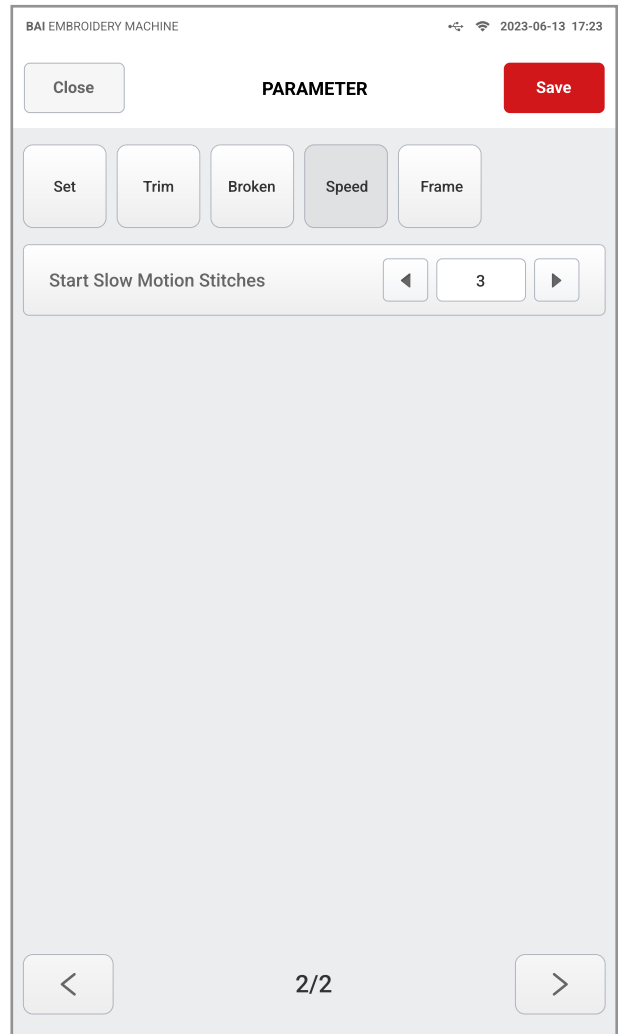
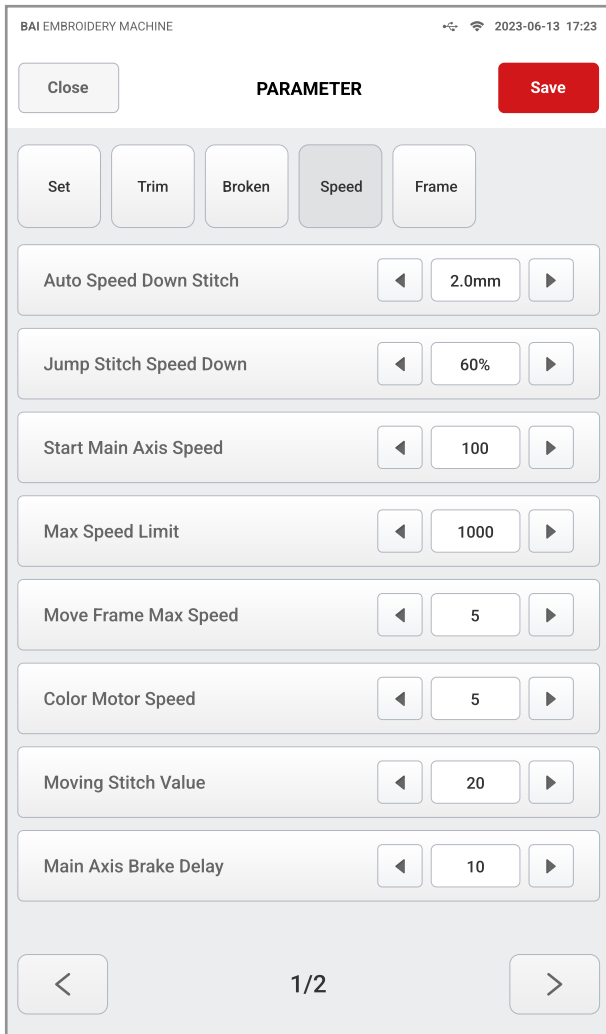

Parameter Name	Parameter Description	Defaults
Auto Speed Down Stitch	Auto Speed Down embroidery after specified stitches number. <ul style="list-style-type: none"> Set to "2.0mm", the embroidery will start to slow down when the stitch step exceeds 2mm. 	2.0mm
Jump Stitch Speed Down	Slow down to the specific percentage of current speed when jump stitches continuously. <ul style="list-style-type: none"> Set the percentage of Jump Stitch Speed Down. 	60%

Parameter Name	Parameter Description	Defaults
Start Main Axis Speed	Speed of main axis at start and stop. <ul style="list-style-type: none">• The more speed set, the longer trimming length.	100
Main Axis Max Speed	Maximum speed setting of main axis (limited by mechanical parameters) <ul style="list-style-type: none">• Set the maximum speed for embroidery.	1000
Move Frame Max Speed	Set the high speed for frame moving. <ul style="list-style-type: none">• The larger the value, the faster the speed.	5
Color Motor Speed	The speed of color change motor. <ul style="list-style-type: none">• The larger the value, the faster the speed.	5
Move Stitch Value	Needle step change speed adjustment within how many consecutive stitches. Speed of stitch changing in continuous stitches. <ul style="list-style-type: none">• The larger the value, the slower the speed change.	20
Main Axis Brake Delay	The time required for the main axis to stop. <ul style="list-style-type: none">• The larger the value, the later the angle of the stop position.	10
Start Slow Motion Stitches	When embroidery starts, move slowly for a few stitches and the main axis starts to speed up. <ul style="list-style-type: none">• The larger the value, the later main axis will accelerate.	3

BAI EMBROIDERY MACHINE 2023-06-13 17:23

Close PARAMETER Save

Set Trim Broken Speed Frame

Type	X Center	Y Center	X Size	Y Size	R	Operate
CAP1	112	-25	280	75	0	🗑️
CAP2	0	0	0	0	0	🗑️
T1	112	-133	60	60	30	🗑️
T2	112	-133	100	100	50	🗑️
T3	112	-133	120	120	60	🗑️
T4	112	-133	160	160	80	🗑️
T5	112	-133	260	138	80	🗑️
TMAX	112	-138	340	340	80	🗑️
F	115	20	500	400	0	🗑️
C1	0	0	0	0	0	🗑️
C2	0	0	0	0	0	🗑️
C3	0	0	0	0	0	🗑️
C4	0	0	0	0	0	🗑️
C5	0	0	0	0	0	🗑️

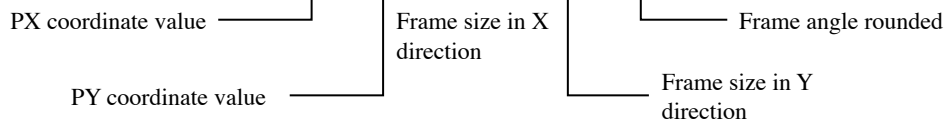

Description

After confirming the size of the embroidery frame and the coordinates of the center position, set the embroidery frame.

- For no rounding corners, R is set to 0.
- The coordinates of Xcenter and Ycenter of embroidery frames of the same type are the same, but the sizes of Xsize and Ysize are different.
- The size of the input Xsize and Ysize should be 30mm smaller than the actual embroidery frame as a safety distance.

i It is not recommended to adjust Xcenter and Ycenter coordinates easily.

Add Frame Manually

1 Put backing fabric.

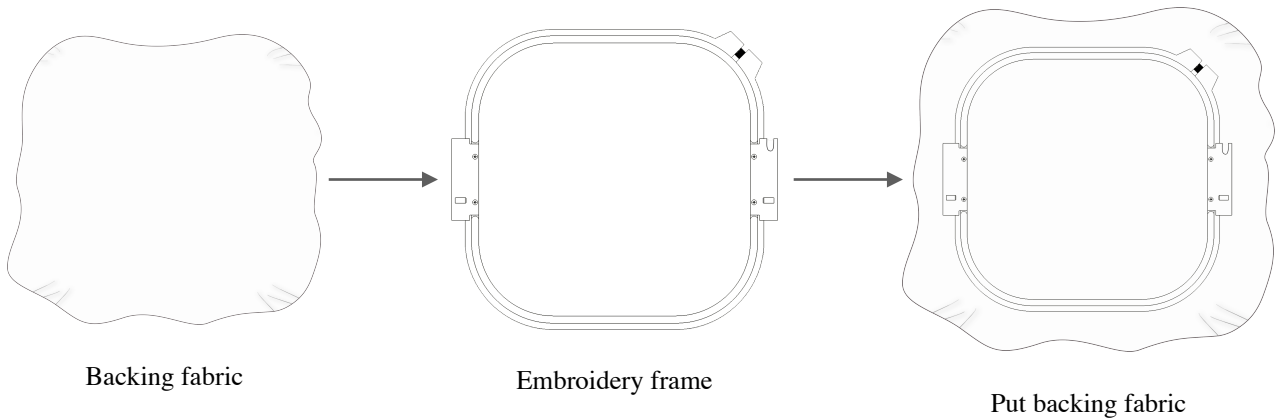

2 Measure the center point of the frame and record the dimensions in the X and Y directions (in mm).

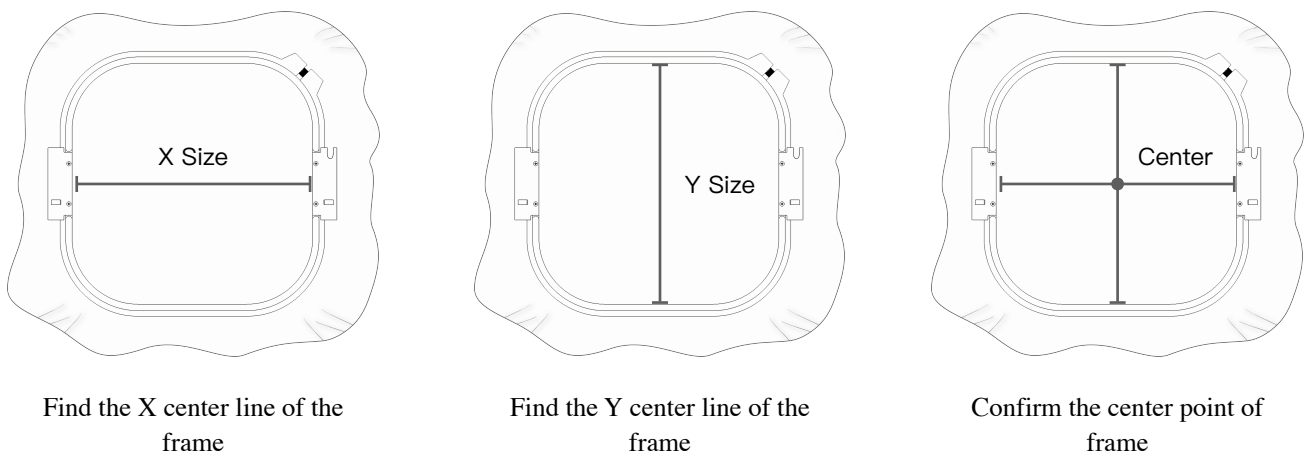

3 Calculate the frame circle (R) and record it.

- No rounding corners, R set to 0.

The length (mm) of the red line segment is the embroidery rounding corners.

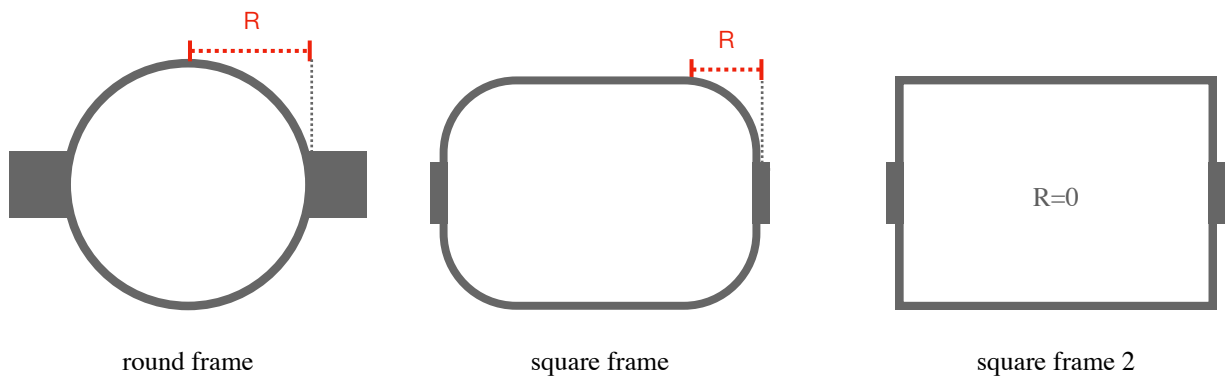

Add Frame Manually

4 Install the embroidery frame to the machine.

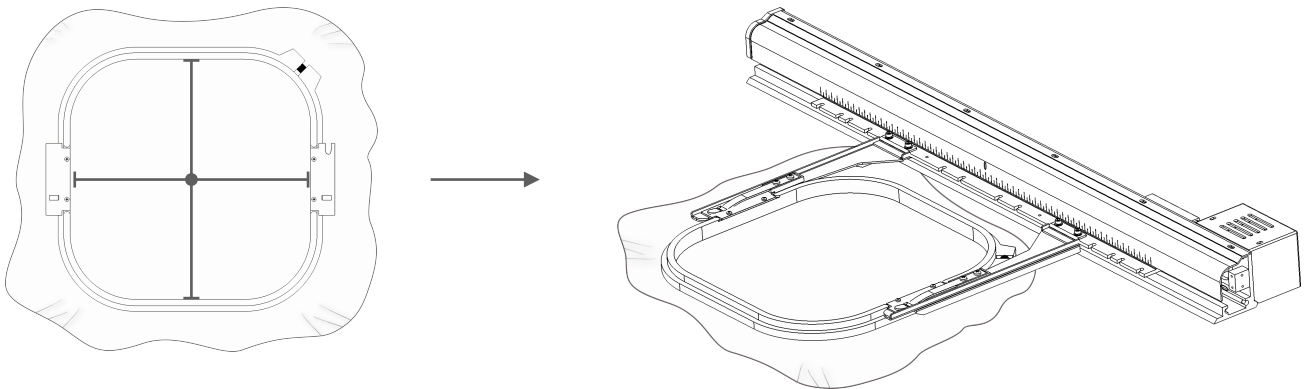

Determine the center point of the frame

5 Find the origin point automatically.



6 Click  Switch to needle 1.

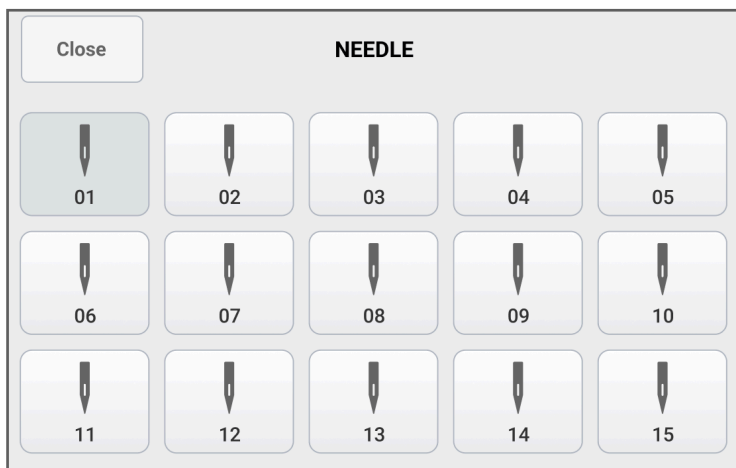

Add Frame Manually

7 Use the direction keys to move the embroidery frame so that needle No. 1 coincides with the center point of the embroidery frame

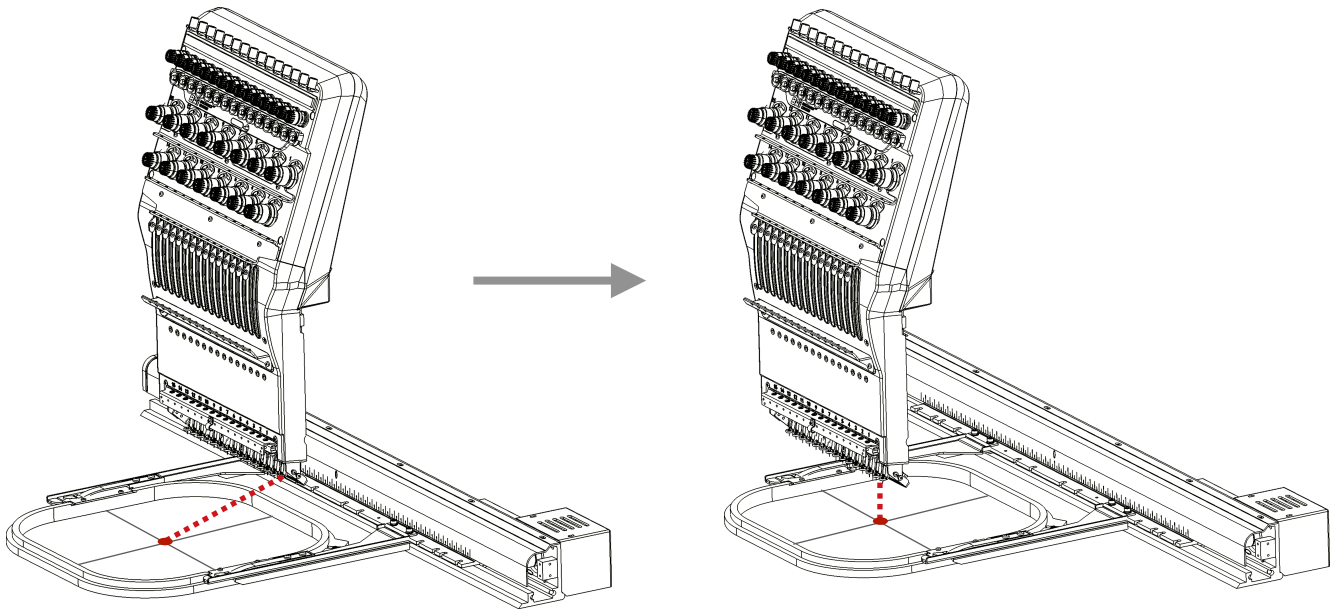

8 Record the values of PX and PY and fill them in the embroidery frame settings.

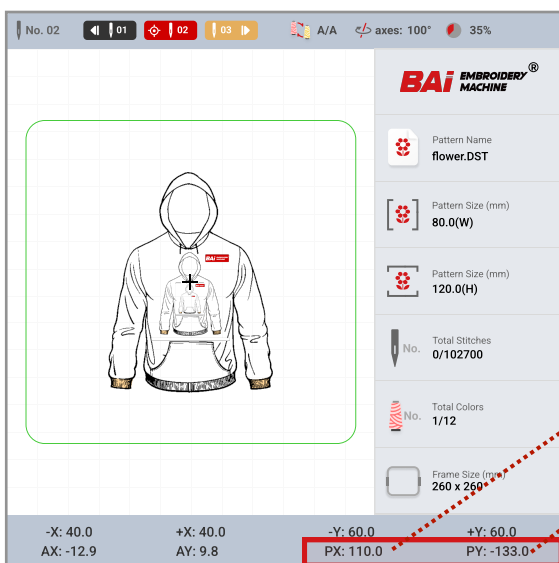

Fill in the values of PX and PY in C1-C5 of the embroidery frame setting.

i C1-C5 are custom embroidery frames, add up to 5 types.

Type	X Center	Y Center	X Size	Y Size	R	Operate
C1	110	113	0	0	0	
C2	0	0	0	0	0	
C3	0	0	0	0	0	
C4	0	0	0	0	0	
C5	0	0	0	0	0	

Add Frame Manually

9 Fill in the recorded X Size, Y Size and circle R values in the embroidery frame settings.

- No rounding corners, R set to 0.
- The size of input X size and Y size should be 30mm smaller than the actual embroidery frame as a safety distance.

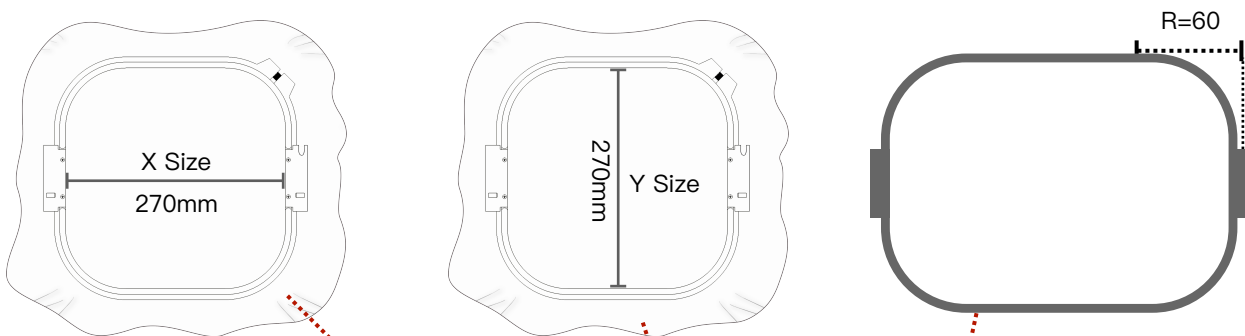

Type	X Center	Y Center	X Size	Y Size	R	Operate
C1	110	-113	240	240	60	
C2	0	0	0	0	0	
C3	0	0	0	0	0	
C4	0	0	0	0	0	
C5	0	0	0	0	0	

10 Click save after the adjustment is complete



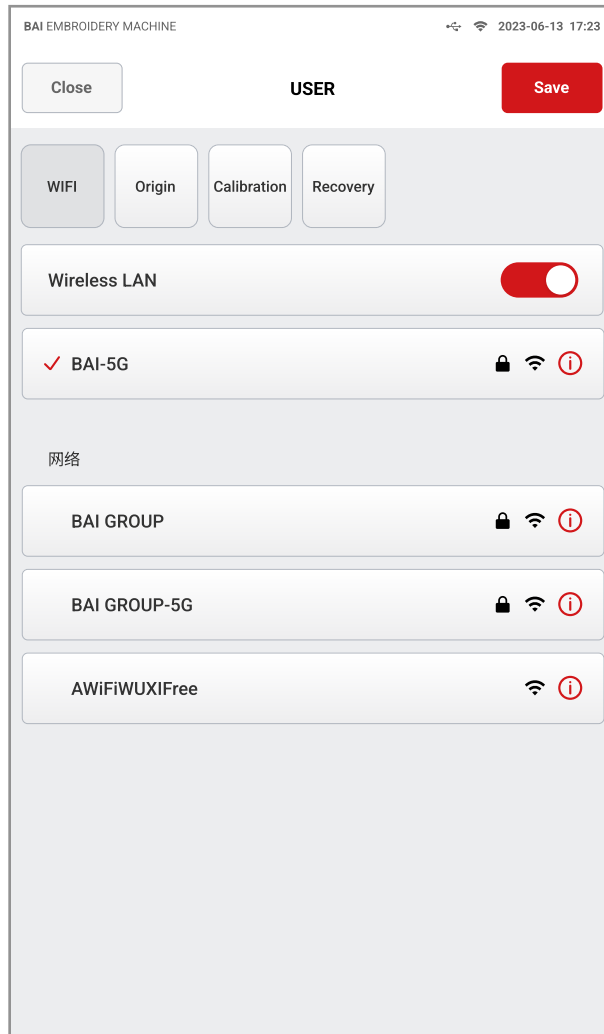

Description

It is used to connect computer and embroidery machine for pattern transmission control.

- Install matched Institch-Link software firstly.

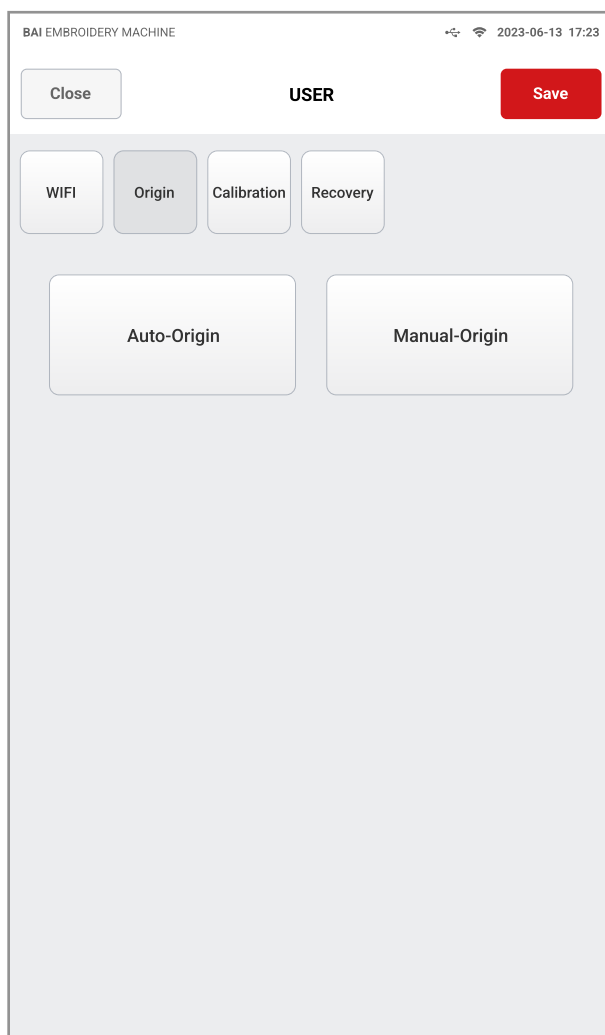

Description

The absolute origin is to use the frame limit to detect the absolute position of the embroidery frame, so as to ensure that after an unexpected situation occurs in the middle of embroidery, the power-off recovery embroidery can be used to carry out accurate continuous embroidery.



Find The Origin Point Automatically

- 1 Click Auto-Origin.
- 2 Click Ok.

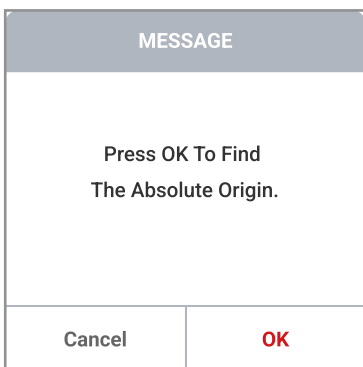

3 The embroidery frame automatically finds the absolute position according to the position of the limit photocoupler.

- This operation is mainly used to manually set the frame parameters.

4 Set the current point as the absolute origin. The PX and PY coordinates become 0,0.



Find The Origin Point Manually

- 1 Move the embroidery frame to the desired position.
- 2 Click manual-origin.
- 3 Click ok.

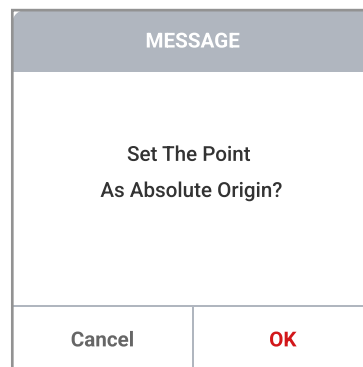

4 Set the current point as the absolute origin. The PX and PY coordinates become 0,0.



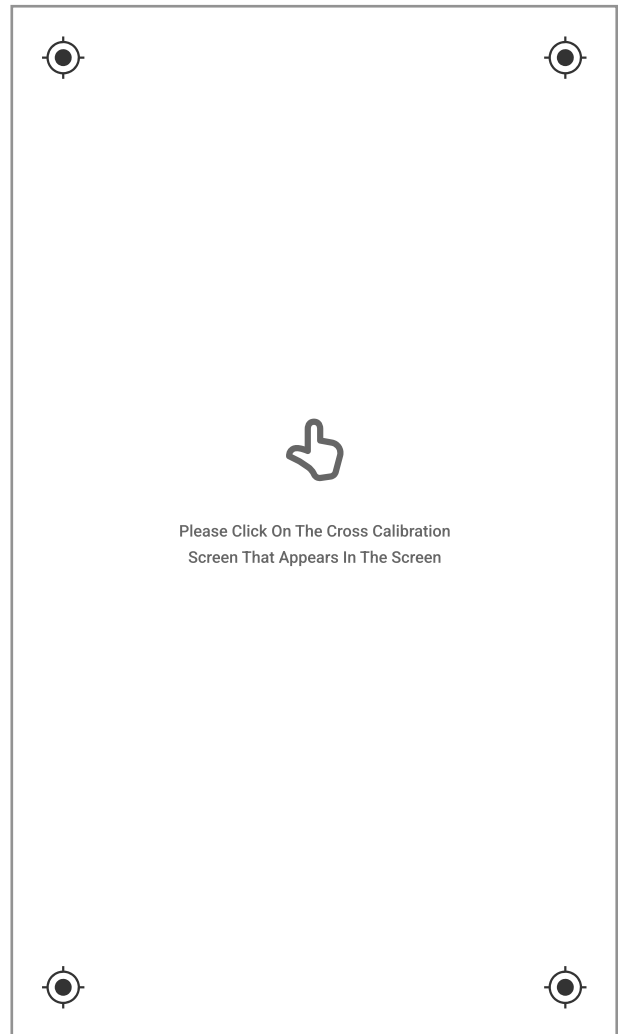
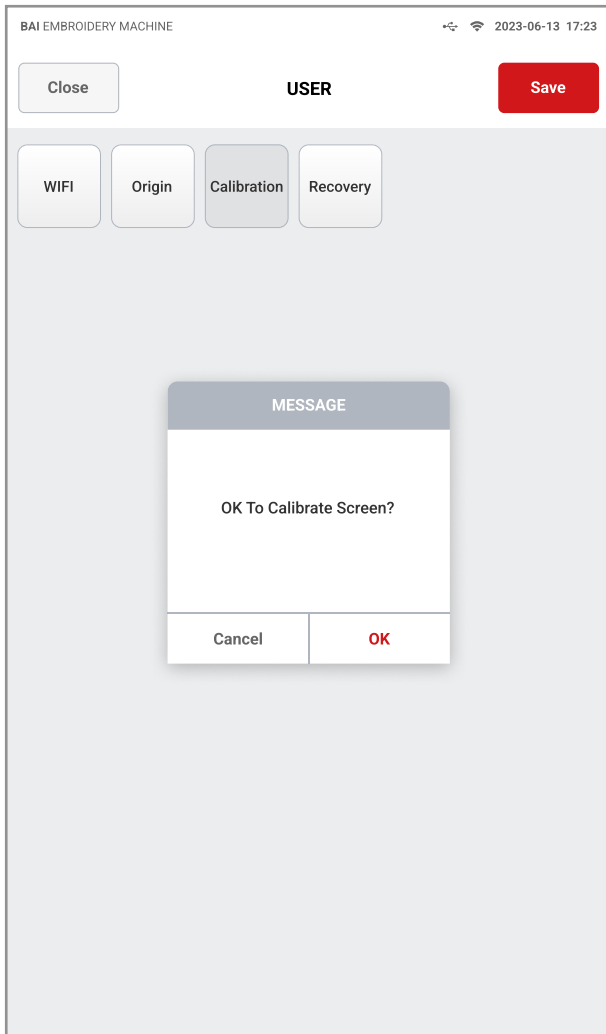

Description

- After the touch screen is used for a period of time, data drift may occur, resulting in inaccurate key clicks, which can be solved by calibrating the touch screen.
- When calibrating the touch screen, the clicked position on the screen must be exactly the same as the center of the displayed cross, otherwise it will affect the touch screen operation in the future.

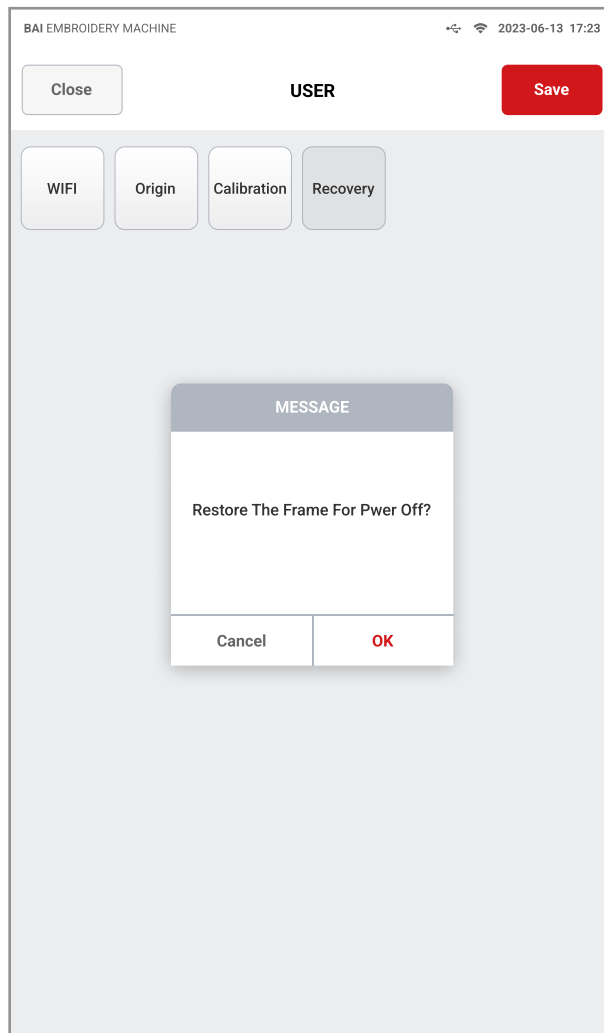

Description

- After a sudden power -off in the middle of embroidery, it can automatically return to last stitch and continue embroidery, without worrying about pattern misalignment.
- Even if the embroidery frame is manually moved after power failure, it can still return to the stop point and continue embroidery.

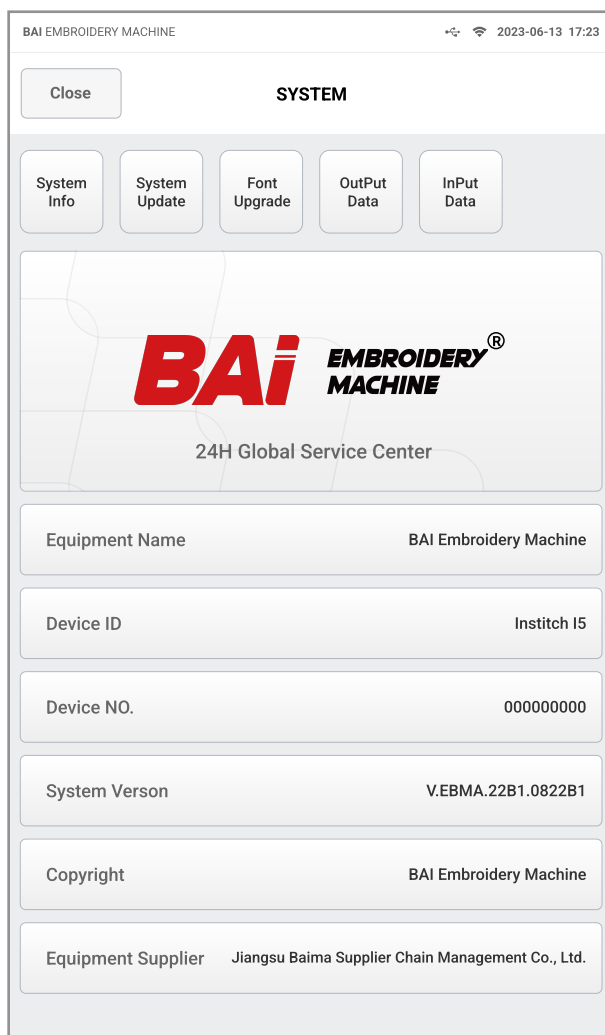

Contents	Description
System Info	Check the machine name, system version number and other information.
System Update	Upgrade the new version of the system.
Font Upgrade	Upgrade the new version of the font.
Output Data	Setted parameters in the control system can be backed up to the U disk.
Input Data	Input the backup information from the U disk to the machine.

System Update

Steps

System
Update

1. Input the upgrade package to the root directory of the USB disk.
2. Insert the USB.
3. Click system update.
4. Click OK.
5. Wait for the upgrade to complete and restart automatically.

Font Upgrade

Steps

Font
Upgrade

1. Input the upgrade package to the root directory of the USB disk.
2. Insert the USB.
3. Click font upgrade.
4. Click OK.
5. Wait for the upgrade to complete and restart automatically.

Output Date

Steps

OutPut
Data

1. Insert the USB.
2. Click output data.
3. Click OK.
4. Wait for the parameters outputted to USB.

Input Date

Steps

InPut
Data

1. Insert the USB.
2. Click input data.
3. Click OK.
4. Wait for the parameters to be inputted into the machine.

Information Of Failures	Reasons Of Failures	Solutions
Connection Timeout	Operation head and the multi-function board signal line connect failure	Check connect cables
	The multi-function board and operation head match failure	Replace the multi-function board
	Multi-function board damaged	Replace the multi-function board
No Response	The touch screen plug connect failure	Re-plug in touch screen plug
	Touch screen damaged	Replace touch screen
Misalignment	Touch screen failure	Re-calibrate the touch screen position
	Touch screen damaged	Replace touch screen
Main axis not in 100°	Main axis stop not at 100°	Click or rotate hand wheel to 100°
Main axis not turn	Servo controller parameter setting error	Check the signal line or power cable of the spindle driver
	The zero signal plate is damp	Check the spindle motor input power
	The zero signal plate damaged	Replace driver or motor
Replace driver or motor	Whether chose to embroider thick material	Reset the parameters of the servo controller
	Whether the spindle locked while in stop state	Clean the oil and dust on the surface of the zero signal plate
	Red light positioning turn on model	Replace the zero signal plate
No 0°	Zero signal plate damaged	Replace the zero signal plate
	Zero signal plate and multi-function board connect failure	Check or replace the connection line
Color time out	Color change motor not turn	Check the color change motor or connection line
	Color changing mechanical parts stuck	Repair or replace stuck mechanical parts
	The color change motor and the power board connect failure	Check or replace the connection line
No needle	Position of the needle detection potentiometer error	Adjust the position of the needle detection potentiometer
	Potentiometer damaged	Replace potentiometer
	Potentiometer and multi-function board connect failure	Check or replace the connection line

Information Of Failures	Reasons Of Failures	Solutions
X motor driver error	X motor driver over-voltage or over-current protection	Check X motor driver and re-power on
	Driver damaged	Replace driver
Y motor driver error	Y motor driver over-voltage or over-current protection	Check Y motor driver and re-power on
	Driver damaged	Replace driver
Trimmer motor stuck	Proximity switch not in place	Manually adjust the thread trimming switch in place
	Proximity switch damaged	Replace proximity switch
Trimmer motor stuck	Motor plug or lines connect failure	Check the plug or lines and re-plug in
	Multi-function board damaged	Replace the multi-function board
	Motor damaged	Replace motor
Hook motor stuck	Motor plug or lines connect failure	Check the plug or lines and re-plug in
	Multi-function board damaged	Replace the multi-function board
	Motor damaged	Replace motor
Broken thread detection error	Optocoupler board installation error	Re-install Optocoupler board
	Optocoupler board damaged	Replace the optocoupler board
	Connect lines or plug failure between optocoupler board and the multi-function board	Check the lines and re-plug in
	Multifunction board damaged	Replace the multifunction board
	Parameters setting error of "top thread breakage detection" or "bottom thread breakage detection"	Adjust to correct embroidery parameters
+X limit error	+X limit	Manually move the embroidery frame in the opposite direction
-X limit error	-X limit	Manually move the embroidery frame in the opposite direction
+Y limit error	+Y limit	Manually move the embroidery frame in the opposite direction
-Y limit error	-Y limit	Manually move the embroidery frame in the opposite direction

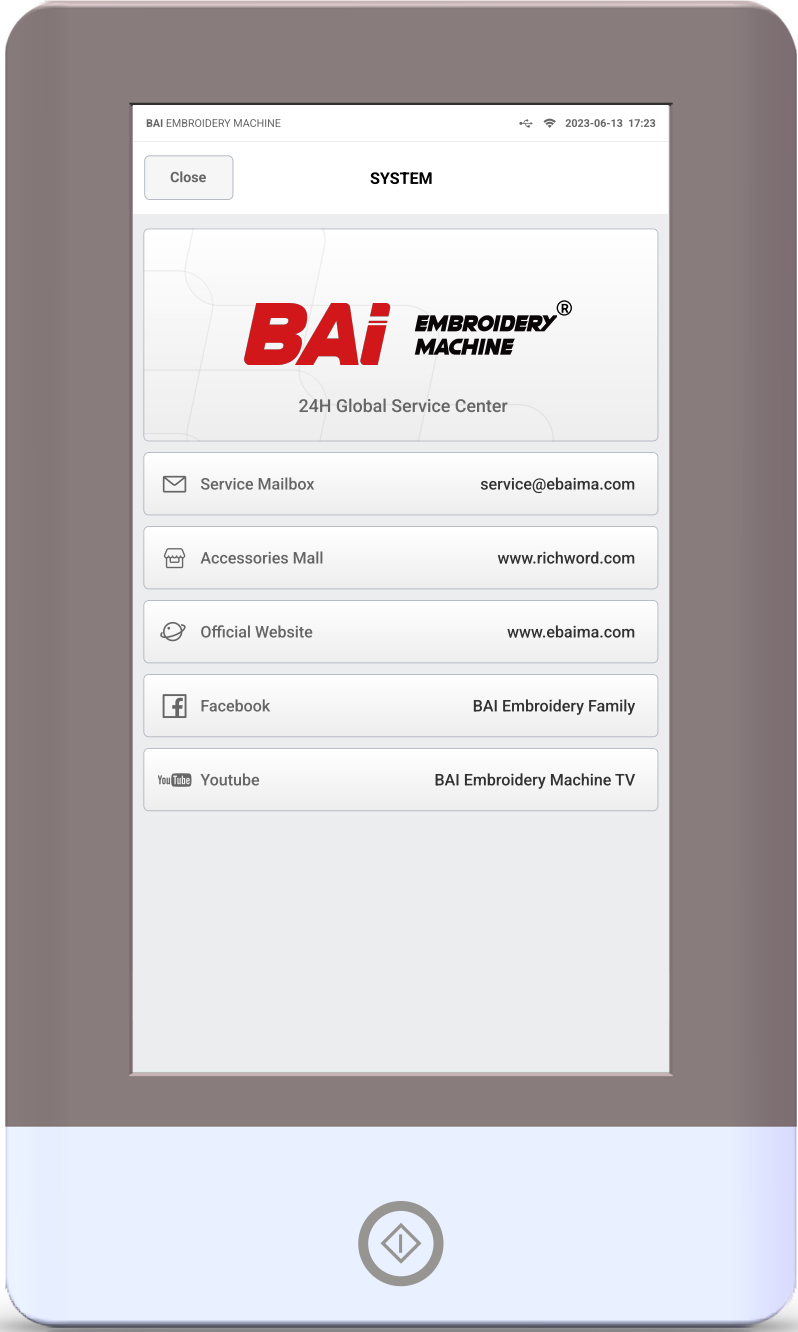

Close

SYSTEM

BAI EMBROIDERY[®]
MACHINE

24H Global Service Center

✉ Service Mailbox service@ebaima.com

🛒 Accessories Mall www.richword.com

🌐 Official Website www.ebaima.com

📘 Facebook [BAI Embroidery Family](#)

📺 Youtube [BAI Embroidery Machine TV](#)

